

WMT Centrifugal Slurry Pumps

Vertical Slurry Pumps

WMT-SP/WMT-SPR & WMT-GPS ranges

ADVANTAGES AND USES OF WMT VERTICAL SUMP PUMPS

WMT heavy duty cantilever Vertical Sump Pumps are designed for handling of corrosive liquids and abrasive slurries at the Mining, Quarrying, Chemical and General Process applications which require extra durability and reliability. The column and pumping head are suspended into the pumped liquid sump while the motor, drive and bearing assembly are dry installed on the top.

A wide range of different impellers (including chokeless) and corrosion/abrasion resistant materials allows tailoring suitable pump for each application and delivering the required head and flow in the most economical way.

FEATURES OF WMT VERTICAL SUMP PUMPS

- Different drive configurations (motor shaft UP or DOWN) to meet customer's requirements.
- Frames power rating up to 110kW.
- Choice of "standard" and "heavy duty" bearing assemblies to avoid critical speed zones.
- No submerged bearings.
- Variety of column/shaft lengths.
 - ✓ Suction extension pipes are available for deeper sumps.
 - ✓ Bottom agitator option available.
- Choice of metal alloy or elastomer wet end parts.
- Designed to handle large particles and high density slurries.
- Cyklo wet-ends for gentle handling of brittle and stringy materials and extra-large particles.
- Continuous operation on "snoring" conditions.
- Painted to SWB or to customer nominated specification.

WMT-SP Pump

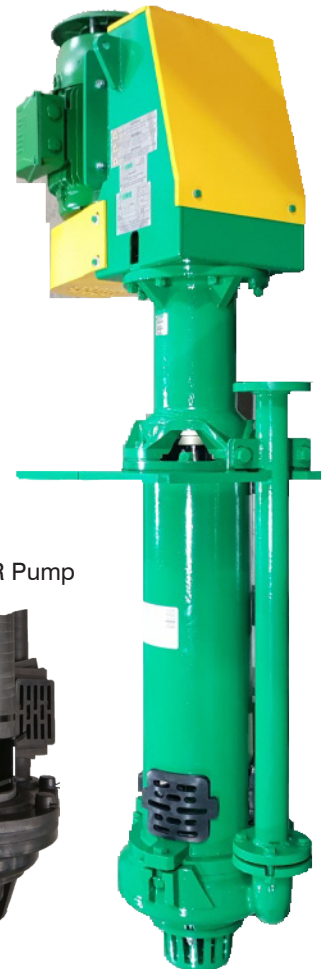

WMT-SPR Pump



For all your slurry pumps,
parts and pump application inquiries
contact our team of product experts at:

WMT / SWB Plus

Phone: +61 2 9929 8811

E: pumps@statewidebearings.com.au

or nearest Statewide Bearings branch

www.statewidebearings.com.au





Above: 65WMT-QV-SP

WMT - SP

WMT-SP Pumps can be supplied on their own heavy duty bearing assemblies with cast housings, or on any of the WMT-GPS range bearing assemblies.

Discharge:

40mm, 65mm, 100mm, 150mm, 200mm

Frame power rating: up to 110kW

WMT - SPR

WMT-SPR Pumps incorporate all the features of the WMT-SP range but are designed specifically for chemically aggressive and abrasive duties and features elastomer covered wet-end components. All fasteners are also covered by special socket head protectors.

Discharge: 40mm, 65mm, 100mm

Frame power rating: up to 75kW



Above: 65WMT-VD-SPR



Above: 100WMT-VEH-GPS

WMT - GPS

WMT-GPS Pumps incorporate standard or heavy duty bearing assemblies with fabricated bearing housings.

Discharge: 40mm, 65mm, 100mm

Frame power rating: up to 75kW

C-DRIVE

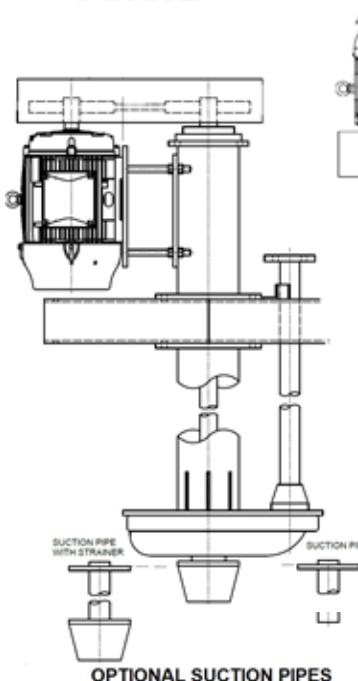

Z-DRIVE

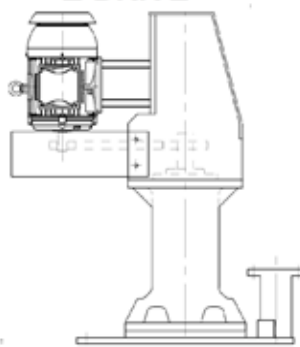

OPTIONAL SUCTION PIPES

Indicative clear water pump performance
Consult SWB for your pump selection

DUTY	PUMP RANGE		
	WMT-SP	WMT-SPR	WMT-GPS
Max Flowrate, m ³ /hr	800	800	300
Max Head, m	45	40	70



GLOBAL SOLUTIONS, LOCAL SERVICE

WA (Head Office) (08) 9352 2200
 QLD State Office (07) 3717 4444
 VIC State Office (03) 8710 9777
 NSW State Office (02) 9616 0000
 SA State Office (08) 8260 6299

