

Miniature Type LM Guide® Models RSR/RSR-W

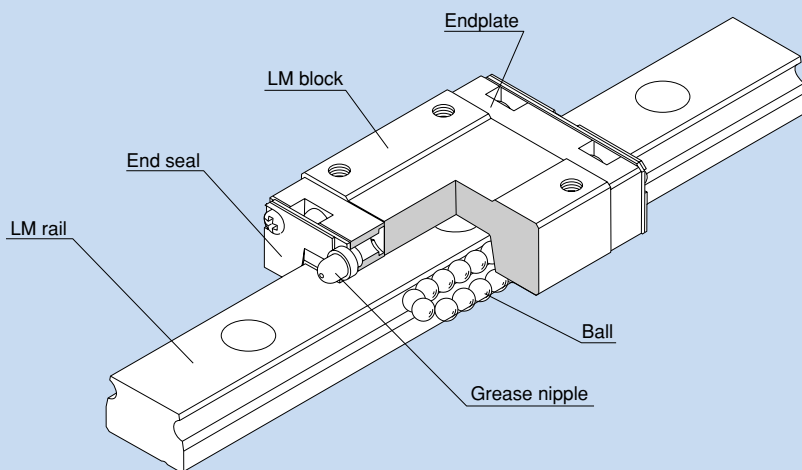

Fig. 1 Structure of Model RSR-V

● Structure and Features

With models RSR and RSR-W, balls roll in two rows of raceways precision-ground on an LM rail and an LM block, and endplates incorporated in the LM block allow the balls to circulate.

Balls circulate in a compact structure and perform infinite linear motion with no limit in stroke.

The LM block is designed to have a shape with high rigidity in a limited space, and in combination with large-diameter balls, demonstrates high rigidity in all directions.

● Ultra compact

The absence of cage displacement, a problem that cross-roller guides and types of ball slides with limited stroke tend to cause, make these models highly reliable LM systems.

● Capable of receiving loads in all directions

These models are capable of receiving loads in all directions, and a single-rail guide can adequately operate under a small moment load. Model RSR-W, in particular, has a greater number of effective balls and a broader LM rail to increase its rigidity against a moment. Thus, it achieves a more compact structure and more durable linear motion than a pair of linear bushes in parallel use.

● Stainless steel type also available

A special type whose LM block, LM rail and balls are made of stainless steel is also available.

Types and Features

Models RSR/RSR-K/RSR-V

These models are standard types.

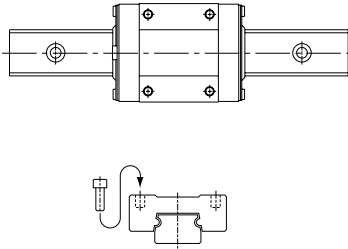

Models RSR-W/WV

It has a longer overall LM block length (L), a broader width (W) and greater rated load and permissible moment than standard types.

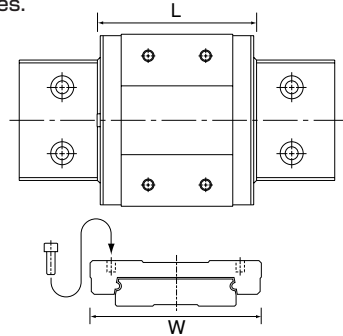

Model RSR-N

It has a longer overall LM block length (L) and a greater rated load than standard types.

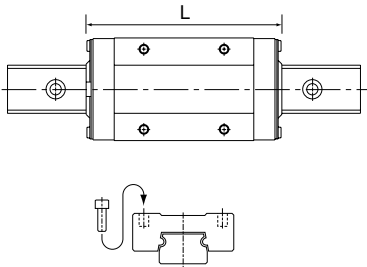

Model RSR-WN

It has a longer overall LM block length (L), a greater rated load than standard types. Achieves the greatest load capacity among the miniature type LM Guide models.

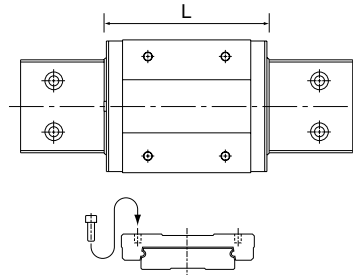

Comparison of Model RSR-W with Other Model Numbers

Locations where a Pair of Linear Bushes Are Used

- Unlike the linear bushes, model RSR-W can be used in a single-rail configuration and allows space saving.
- Since model RSR-W has more load-bearing balls per row and wider LM block and LM rail, thus to achieve high rigidity against an overhung load.
- Accuracy can be achieved simply by mounting the LM rail using bolts. Therefore, the assembly time can be shortened.

Example of comparing model RSR12W with model LM 10 in use

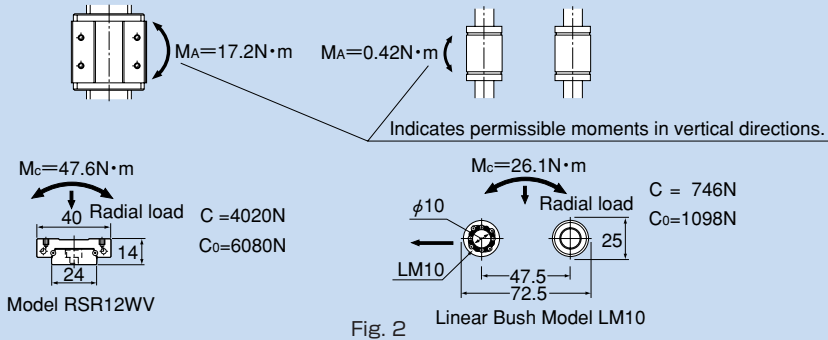

Fig. 2

Locations where a Cross-roller Table Is Used

- Does not show cage displacement even with vertical mount, and capable of performing infinite linear motion.
- Eliminates the need for difficult clearance adjustment and achieves long-term, smooth motion over a long period of time.
- Since the LM block width is large, the model can be used as a miniature table without any modification.

Example of comparing model RSR9WV with model VRM1035 in use

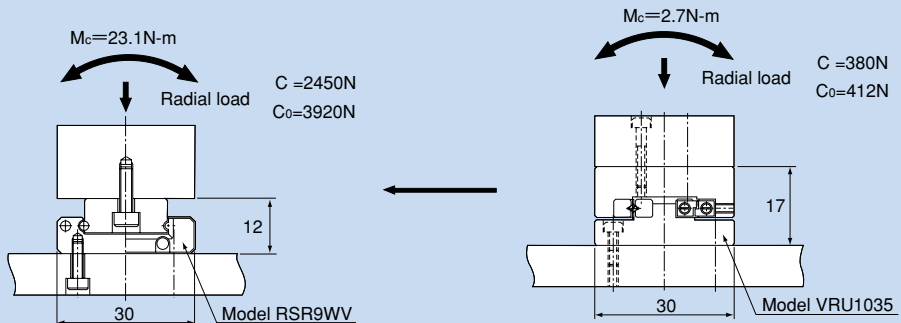

Fig. 3

Rated Loads in All Directions

Model RSR is capable of receiving loads in all four directions: radial, reverse-radial and lateral directions.

The basic load ratings of models RSR3 to 9 are uniform in the four directions (radial, reverse-radial and lateral directions), and their actual values are provided in the dimensional table for RSR.

The basic load ratings of models RSR12 to 20 indicate the values in the radial direction in Fig. 4, and their actual values are provided in the dimensional table for RSR. The values in the reverse-radial and lateral directions are obtained from table 1.

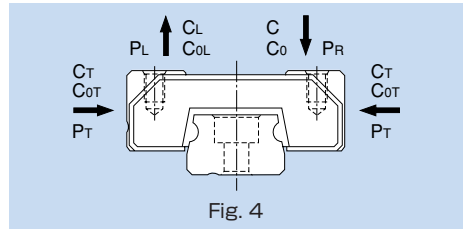

Fig. 4

Table 1 Basic Load Ratings of Models RSR12 to 20 in All Directions

Direction	Basic dynamic load rating	Basic static load rating
Radial direction	C	C ₀
Reverse-radial direction	C _L =0.78C	C _{0L} =0.70C ₀
Lateral direction	C _T =0.78C	C _{0T} =0.71C ₀

Equivalent Load

When the LM block of models RSR3 to 9 receives loads in all four directions simultaneously, the equivalent load is obtained from the equation below.

$$P_E = P_R (P_L) + P_T$$

where

- P_E : Equivalent load (N)
 - Radial direction
 - Reverse-radial direction
 - Lateral direction
- P_R : Radial load (N)
- P_L : Reverse-radial load (N)
- P_T : Lateral load (N)

When the LM block of model RSR12 to 20 receives loads in the radial and lateral directions, or the reverse-radial and lateral directions, simultaneously, the equivalent load is obtained from the equation below.

$$P_E = X \cdot P_R (P_L) + Y \cdot P_T$$

where

- P_E : Equivalent load (N)
 - Radial direction
 - Reverse-radial direction
 - Lateral direction
- P_R : Radial load (N)
- P_L : Reverse-radial load (N)
- P_T : Lateral load (N)
- X/Y axes : Equivalent factor (see tables 2 and 3)

Table 2 Equivalent Factor of Models RSR12 to 20 (When radial and lateral loads are applied)

P _E	X	Y
Equivalent load in radial direction	1	0.83
Equivalent load in lateral direction	1.2	1

Table 3 Equivalent Factor of Models RSR12 to 20 (When reverse-radial and lateral loads are applied)

P _E	X	Y
Equivalent load in radial direction	1	0.99
Equivalent load in lateral direction	1.01	1

Options

Dust Prevention Accessories

THK offers an end seal for model RSR as a dust prevention accessory.
(For details of the end seal, see page a-24.)

Table 4 Symbol of Dust Prevention Accessory for Model RSR

Symbol	Dust prevention accessory
UU	With end seal

Seal resistance value

For the maximum seal resistance value per LM block when a lubricant is applied on seals RSR...UU, refer to the corresponding value provided in table 5.

Table 5 Maximum Seal Resistance Value of Seals RSR...UU
Unit: N

Model No.	Seal resistance value
RSR 5	0.06
RSR 7	0.08
RSR 9	0.1
RSR 12	0.4
RSR 15	0.8
RSR 20	1.0
RSR 3W	0.2
RSR 5W	0.3
RSR 7W	0.4
RSR 9W	0.8
RSR 12W	1.1
RSR 15W	1.3

Dedicated Cap C for LM Rail Mounting Holes

If any of the LM rail mounting holes of an LM Guide is filled with cutting chips or foreign matter, they may enter the LM block structure. Entrance of such foreign matter can be prevented by covering each LM rail mounting hole with the dedicated cap so that the top of the mounting holes is on the same level as the LM rail top face.

Since the dedicated cap C for LM rail mounting holes uses a special synthetic resin with high oil resistance and high wear resistance, it is highly durable.

When placing an order, specify the desired cap type with the corresponding cap number indicated in table 6.

For the procedure for mounting the cap, see page a-22.

Table 6 Major Dimensions of Dedicated Cap C

Model No.	Cap C model No.	Bolt used	Major dimensions mm	
			D	H
RSR 9W	C3	M3	6.3	1.2
RSR 12	C3	M3	6.3	1.2
RSR 15	C3	M3	6.3	1.2
RSR 20	C5	M5	9.8	2.4

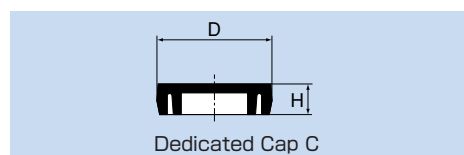

QZ Lubricator™

When QZ Lubricator is required, specify the desired type with the corresponding symbol indicated in table 7 (for details of QZ Lubricator, see pages a-19 and a-20).

For supported LM Guide model numbers for QZ Lubricator and overall LM block length with QZ Lubricator attached (dimension L), see page a-422.

Table 7 Parts Symbol for Model RSR with QZ Lubricator Attached

Symbol	Dust prevention accessories for LM Guide with QZ Lubricator attached
QZUU	With end seal + QZ

Stopper

With miniature LM Guide models RSR/RSR-W, balls will fall off if the LM block is removed from the LM rail.

To prevent the LM block from being pulled out, end pieces are mounted before shipment. If removing the stopper when using the LM Guide, be sure that the LM block will not overrun.

Table 8 Dimensional Table for Stopper (Type C) for Model RSR

Unit: mm

Model No.	A	B	C
RSR 7	11	5	7.7
RSR 9	13	6	9.5
RSR 12	16	7	12.5
RSR 15	19	7	14.5
RSR 20	25	7	20.0
RSR 7W	18	6	8.2
RSR 9W	23	7	11.5
RSR 12W	29	7	13.5
RSR 15W	46	7	14.5

Note: The stopper for models RSR3M/N, 5M/N and 5W uses an O-ring, while that for model RSR3W uses a silicone tube.

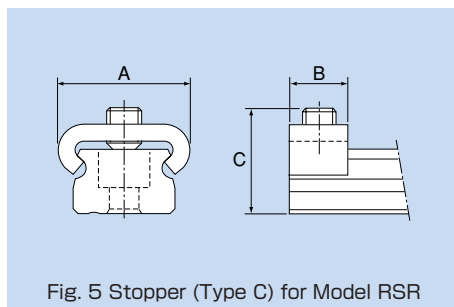

Fig. 5 Stopper (Type C) for Model RSR

Accuracy of the Mounting Surface

Model RSR uses Gothic arch grooves in the ball raceways. When two rails of RSR are used in parallel, any error in accuracy of the mounting surface may increase rolling resistance and negatively affect the smooth motion of the guide. For specific accuracy of the mounting surface, see Section 7.3 "Permissible Error of the Mounting Surface" on page a-62.

When using this model in locations where it is difficult to obtain satisfactory accuracy of the mounting surface, we recommend using types RSR···A (semi standard) whose ball raceways have circular-arc grooves (avoid using these types in a single-rail configuration).

For specific accuracy of the mounting surface for types RSR···A, see Section 7.3 "Permissible Error of the Mounting Surface" on page a-62.

Standard Length and Maximum Length of the LM Rail

Table 9 shows the standard lengths and the maximum lengths of model RSR variations.

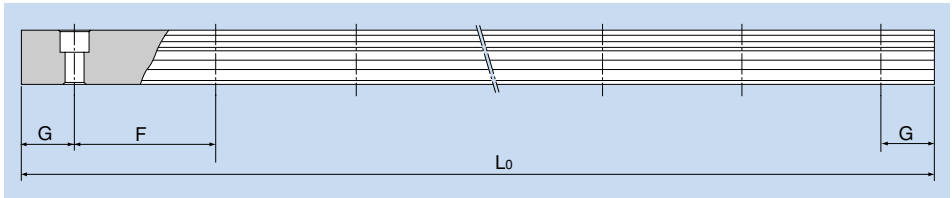
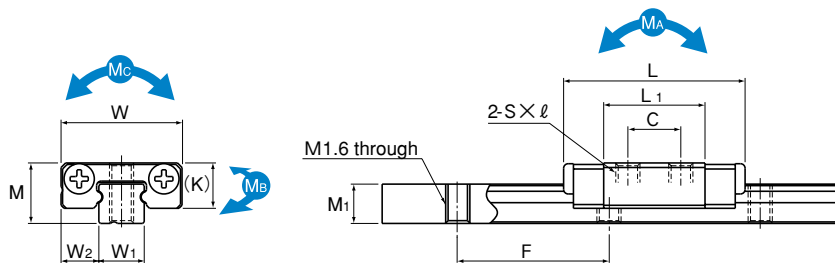

Table 9 Standard Length and Maximum Length of the LM Rail for Model RSR/RSR-W Unit: mm

Model No.	RSR 3	RSR 5	RSR 7	RSR 9	RSR 12	RSR 15	RSR 20	RSR 3W	RSR 5W	RSR 7W	RSR 9W	RSR 12W	RSR 15W
Standard LM rail length (L ₀)	30	40	40	55	70	70	220	40	50	50	50	70	110
	40	55	55	75	95	110	280	55	70	80	80	110	150
	60	70	70	95	120	150	340	70	90	110	110	150	190
	80	100	85	115	145	190	460		110	140	140	190	230
	100	130	100	135	170	230	640		130	170	170	230	270
		160	130	155	195	270	880		150	200	200	270	310
				175	220	310	1000		170	260	260	310	430
				195	245	350			290	290	390	550	530
				275	270	390				320	470	670	790
				375	320	430							
					370	470							
					470	550							
					570	670							
						870							
Standard pitch F	10	15	15	20	25	40	60	15	20	30	30	40	40
G	5	5	5	7.5	10	15	20	5	5	10	10	15	15
Max length	200	200	300	1000	1340	1430	1800	100	200	400	1000	1430	1800

Note 1: The maximum length varies with accuracy grades. Contact THK for details.

Note 2: The LM rail mounting hole of model RSR3 is an M1.6 through hole.



Model RSR3M

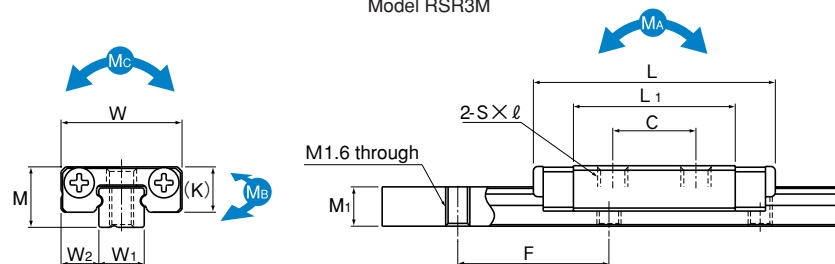

Model RSR3N

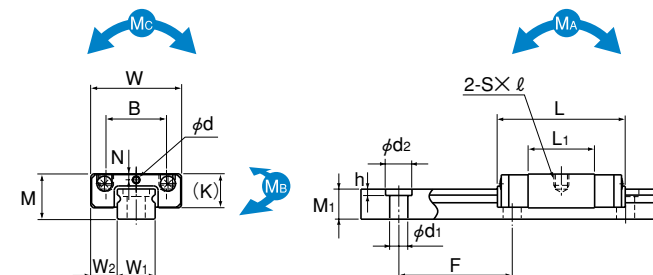

Model RSR5M

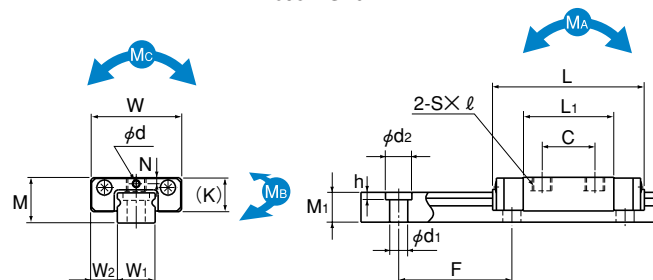

Model RSR5N

Unit: mm

Model No.	External dimensions			LM block dimensions										LM rail dimensions					Basic load rating		Static permissible moment N-m*					Mass	
	Height	Width	Length	B	C	S x l	L ₁	T	K	N	E	Greasing hole d	Grease nipple	Width	Height	Pitch	d ₁ x d ₂ x h	C	C ₀	M _A		M _B		M _C	LM block	LM rail	
	M	W	L											W ₁	W ₂	M ₁	F			1 block	2 blocks in close contact	1 block	2 blocks in close contact	1 block	kg	kg/m	
RSR 3M	4	8	12	—	3.5	M1.6x1.3	6.7	—	3	—	—	—	—	3 ⁰ _{-0.02}	2.5	2.6	10	—	0.18	0.27	0.293	2.11	0.293	2.11	0.45	0.0011	0.055
RSR 3N			16		5.5	M2x1.3	10.7		—										—	—	—	—	—	—	—	—	
RSR 5M	6	12	16.9	8	—	M2x1.5	8.8	—	4.5	0.8	—	0.8	—	5 ⁰ _{-0.02}	3.5	4	15	2.4x3.5x1	0.32	0.59	0.884	6.51	0.884	6.51	1.53	0.003	0.14
RSR 5N			20.1		7	M2.6x1.8	12		—	—		—						—	—	—	—	—	—	—	—	—	

Note Since stainless steel is used in the LM block, LM rail and balls, these models are highly resistant to corrosion and environment. Models RSR3M and 3N do not have a greasing hole. When lubricating them, apply a lubricant directly to the LM rail raceways. To secure the LM rail of models RSR5M and 5N, use cross-recessed head screws for precision equipment (No. 0 pan head screw, class 1) M2.

Note Static permissible moment* 1 block: static permissible moment value with 1 LM block
2 blocks: static permissible moment value with 2 blocks closely contacting with each other

Model number coding **2 RSR5 M UU C1 +130L P M- II**

1 2 3 4 5 6 7 8

- 1 No. of LM blocks used on the same rail
- 2 Model number
- 3 Dust prevention accessory symbol (see page a-412)
- 4 Radial clearance symbol (see page a-35)
- 5 LM rail length (in mm)
- 6 Accuracy symbol (see page a-45)
- 7 LM rail is made of stainless steel
- 8 Symbol for No. of rails used on the same plane

Note This model number indicates that a single-rail unit constitutes one set (i.e., required number of sets when 2 rails are used in parallel is 2 at a minimum).

Recommended tightening torque when mounting the LM rail/block

Table 10 shows recommended bolt tightening torques when mounting the LM block and LM rail of models RSR3M/3N.

Table 10 Recommended Tightening Torques of Mounting Bolts

Model No. of screw	Recommended tightening torque (N-m)
M1.6	0.09
M2	0.19

Note: Applicable to austenitic stainless steel hexagon socket bolts.

Model RSR-M
Model RSR-KM
Model RSR-VM
Model RSR-N

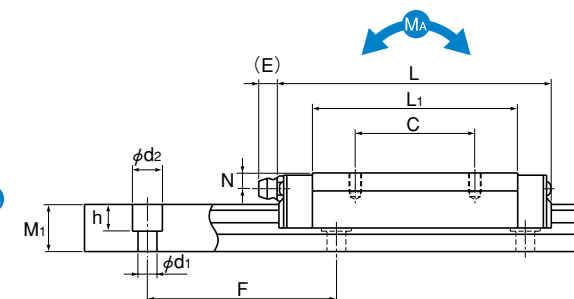
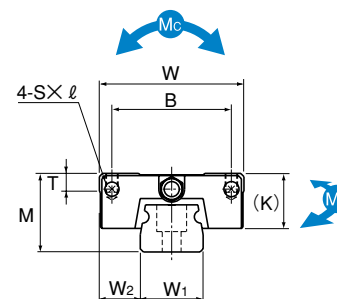
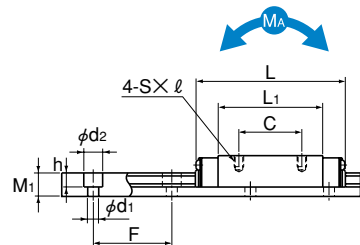
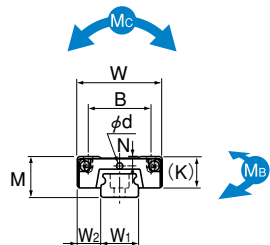

Models RSR7 to 12N/7M/9KM/12VM

Models RSR15,20VM/N

Unit: mm

Model No.	External dimensions			LM block dimensions										LM rail dimensions				Basic load rating		Static permissible moment N-m*			Mass				
	Height M	Width W	Length L	B	C	S × ℓ	L ₁	T	K	N	E	Greasing hole d	Grease nipple	Width W ₁	Height W ₂	Pitch M ₁	F	d ₁ × d ₂ × h	C	C ₀	M _A	M _B	M _C	LM block kg	LM rail kg/m		
RSR 7M RSR 7N	8	17	23.4 33	12	8 13	M2×2.5	13.4 23	—	6.5	1.7	—	1.2	—	7 ⁰ _{-0.02}	5	4.7	15	2.4×4.2×2.3	0.88 1.59	1.37 2.5	2.93 8.68	20.8 49.9	2.93 8.68	20.8 49.9	5 9.12	0.013 0.018	0.23
RSR 9KM RSR 9N	10	20	30.8 41	15	10 16	M3×3	19.8 29.8	—	7.8	2.4	—	1.5	—	9 ⁰ _{-0.02}	5.5	5.5	20	3.5×6×3.3	1.47 2.6	2.25 3.96	7.34 18.4	43.3 97	7.34 18.4	43.3 97	10.4 18.4	0.018 0.027	0.32
RSR 12VM RSR 12N	13	27	35 47.7	20	15 20	M3×3.5	20.6 33.3	—	10	3	—	2	—	12 ⁰ _{-0.025}	7.5	7.5	25	3.5×6×4.5	2.65 4.3	4.02 6.65	11.4 28.9	74.9 163	10.1 25.5	67.7 145	19.2 31.8	0.037 0.055	0.58
RSR 15VM RSR 15N	16	32	43 61	25	20 25	M3×4	25.7 43.5	—	12	3.5	3.6 3.7	—	PB107	15 ⁰ _{-0.025}	8.5	9.5	40	3.5×6×4.5	4.41 7.16	6.57 10.7	23.7 63.1	149 330	21.1 55.6	135 293	38.8 63	0.069 0.093	0.925
RSR 20VM RSR 20N	25	46	66.5 86.3	38	38	M4×6	45.2 65	5.7	17.5	5	6.4	—	A-M6F	20 ⁰ _{-0.03}	13	15	60	6×9.5×8.5	8.82 14.2	12.7 20.6	75.4 171	435 897	66.7 151	389 795	96.6 157	0.245 0.337	1.95

Note Since stainless steel is used in the LM block, LM rail and balls, these models are highly resistance to corrosion and environment.

Note Static permissible moment* 1 block: static permissible moment value with 1 LM block
2 blocks: static permissible moment value with 2 blocks closely contacting with each other

Model number coding **2 RSR15V M UU C1 +230L P M- II**

1 2 3 4 5 6 7 8

- 1 No. of LM blocks used on the same rail
- 2 Model number
- 3 Dust prevention accessory symbol (see page a-412)
- 4 Radial clearance symbol (see page a-35)
- 5 LM rail length (in mm)
- 6 Accuracy symbol (see page a-45)
- 7 LM rail is made of stainless steel
- 8 Symbol for No. of rails used on the same plane

Note This model number indicates that a single-rail unit constitutes one set (i.e., required number of sets when 2 rails are used in parallel is 2 at a minimum).

Model RSR-WM (WV)
Model RSR-WVM
Model RSR-WM

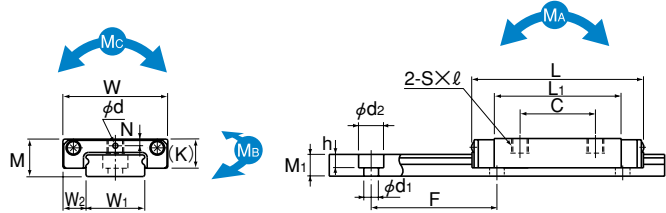

Models RSR3 to 7WM/WN

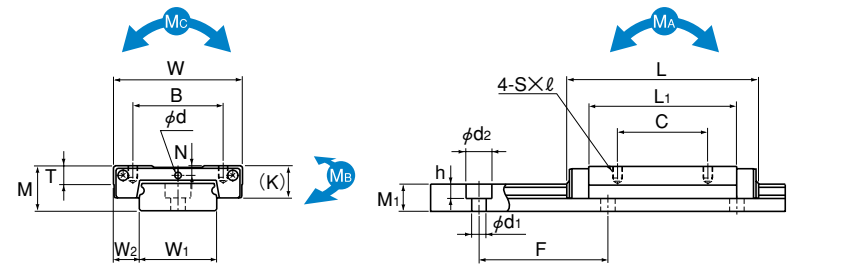

Models RSR9,12WV/WVM/WN

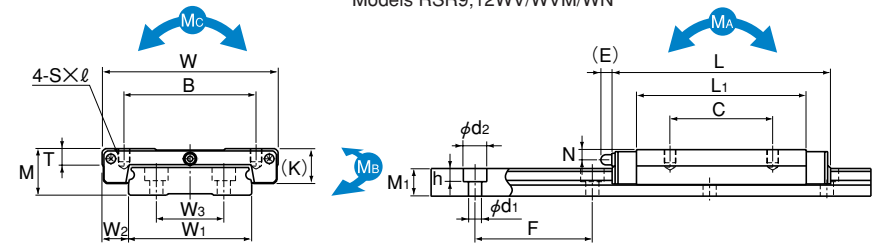

Models RSR15WV/WVM/WN

Unit: mm

Model No.	External dimensions			LM block dimensions										LM rail dimensions					Basic load rating		Static permissible moment N-m*					Mass		
	Height	Width	Length	B	C	S × l	L ₁	T	K	N	E	Greasing hole d	Grease nipple	Width	Width	Height	Pitch	C	C ₀	M _A	M _B	M _C	LM block	LM rail				
	M	W	L											W ₁	W ₂	W ₃	M ₁	F	d ₁ × d ₂ × h	kN	kN	1 block	2 blocks in close contact	1 block	2 blocks in close contact	1 block	kg	kg/m
**RSR 3WM	4.5	12	14.9	—	4.5	M2×1.7	8.5	—	3.5	0.8	—	0.8	—	6 ⁰ _{-0.02}	3	—	2.6	15	2.4×4×1.5	0.25	0.47	0.668	4.44	0.668	4.44	1.48	0.002	0.12
**RSR 3WN	4.5	12	19.9	—	8	M2×1.7	13.3	—	3.5	0.8	—	0.8	—	6 ⁰ _{-0.02}	3	—	2.6	15	2.4×4×1.5	0.39	0.75	1.57	9.06	1.57	9.06	2.36	0.003	0.12
**RSR 5WM	6.5	17	22.1	—	6.5	M3×2.3	13.7	—	5	1.1	—	0.8	—	10 ⁰ _{-0.025}	3.5	—	4	20	3×5.5×3	0.51	0.96	1.97	13.1	1.97	13.1	4.89	0.007	0.28
**RSR 5WN	6.5	17	28.1	—	11	M3×2.3	19.7	—	5	1.1	—	0.8	—	10 ⁰ _{-0.025}	3.5	—	4	20	3×5.5×3	0.75	1.4	4.06	23.5	4.06	23.5	7.13	0.01	0.28
**RSR 7WM	9	25	31	—	12	M4×3.5	20.4	—	7	1.6	—	1.2	—	14 ⁰ _{-0.05}	5.5	—	5.2	30	3.5×6×3.2	1.37	2.16	7.02	40.7	7.02	40.7	15.4	0.021	0.51
**RSR 7WN	9	25	40.9	—	18	M4×3.5	30.3	—	7	1.6	—	1.2	—	14 ⁰ _{-0.05}	5.5	—	5.2	30	3.5×6×3.2	2.04	3.21	14.7	77.6	14.7	77.6	22.9	0.026	0.51
RSR 9WV	12	30	39	21	12	M2.6×3	27	—	7.8	2	—	1.6	—	18 ⁰ _{-0.05}	6	—	7.5	30	3.5×6×4.5	2.45	3.92	16	92.9	16	92.9	36	0.035	1.08
**RSR 9WVM	12	30	39	21	12	M2.6×3	27	—	7.8	2	—	1.6	—	18 ⁰ _{-0.05}	6	—	7.5	30	3.5×6×4.5	2.45	3.92	16	92.9	16	92.9	36	0.035	1.08
**RSR 9WN	12	30	50.7	23	24	M3×3	38.7	—	7.8	2	—	1.6	—	18 ⁰ _{-0.05}	6	—	7.5	30	3.5×6×4.5	3.52	5.37	31	161	31	161	49.4	0.051	1.08
RSR 12WV	14	40	44.5	15	15	M3×3.5	30.9	—	10	3	—	2	—	24 ⁰ _{-0.05}	8	—	8.5	40	4.5×8×4.5	4.02	6.08	24.5	138	21.7	123	59.5	0.075	1.5
**RSR 12WVM	14	40	44.5	28	15	M3×3.5	30.9	4.5	10	3	—	2	—	24 ⁰ _{-0.05}	8	—	8.5	40	4.5×8×4.5	4.02	6.08	24.5	138	21.7	123	59.5	0.075	1.5
**RSR 12WN	14	40	59.5	28	28	M3×3.5	45.9	—	10	3	—	2	—	24 ⁰ _{-0.05}	8	—	8.5	40	4.5×8×4.5	5.96	9.21	53.9	274	47.3	242	90.1	0.101	1.5
RSR 15WV	16	60	55.5	20	20	M4×4.5	38.9	—	12	3.5	3	—	PB107	42 ⁰ _{-0.05}	9	23	9.5	40	4.5×8×4.5	6.66	9.8	50.3	278	44.4	248	168	0.17	3
**RSR 15WVM	16	60	55.5	45	20	M4×4.5	38.9	5.6	12	3.5	3	—	PB107	42 ⁰ _{-0.05}	9	23	9.5	40	4.5×8×4.5	6.66	9.8	50.3	278	44.4	248	168	0.17	3
**RSR 15WN	16	60	74.5	35	35	M4×4.5	57.9	—	12	3.5	3	—	PB107	42 ⁰ _{-0.05}	9	23	9.5	40	4.5×8×4.5	9.91	14.9	110	555	97.3	490	255	0.21	3

Note *** indicates that since stainless steel is used in the LM block, LM rail and balls, these models are highly resistance to corrosion and environment.
To secure the LM rail of models RSR3WM and 3WN, use cross-recessed head screws for precision equipment (No. 0 pan head screw, class 1) M2.

Note Static permissible moment* 1 block: static permissible moment value with 1 LM block
2 blocks: static permissible moment value with 2 blocks closely contacting with each other

Model number coding **2 RSR12WV M UU C1 +310L H M**

1 2 3 4 5 6 7

- 1 No. of LM blocks used on the same rail
- 2 Model number
- 3 Dust prevention accessory symbol (see page a-412)
- 4 Radial clearance symbol (see page a-35)
- 5 LM rail length (in mm)
- 6 Accuracy symbol (see page a-45)
- 7 LM rail is made of stainless steel

Overall LM Block Length with Options

■ Overall LM Block Length (Dimension L) of Model RSR with a Dust Prevention Accessory Attached

Unit: mm

Model No.	UU
RSR 3M	—
RSR 3N	—
RSR 3WM	14.9
RSR 3WN	19.9
RSR 5M	16.9
RSR 5N	20.1
RSR 5WM	22.1
RSR 5WN	28.1
RSR 7M	23.4
RSR 7N	33
RSR 7WM	31
RSR 7WN	40.9
RSR 9KM	30.8
RSR 9N	41
RSR 9WV	39
RSR 9WVM	39
RSR 9WN	50.7

Model No.	UU
RSR 12VM	35
RSR 12N	47.7
RSR 12WV	44.5
RSR 12WVM	44.5
RSR 12WN	59.5
RSR 15VM	43
RSR 15N	61
RSR 15WV	55.5
RSR 15WVM	55.5
RSR 15WN	74.5
RSR 20VM	66.5
RSR 20N	86.3

Note: "—" indicates not available.

■ Overall LM Block Length (Dimension L) of Model RSR with QZ Lubricator Attached

Unit: mm

Model No.	QZUU
RSR 9	41
RSR 9N	51
RSR 9W	49
RSR 9WN	61
RSR 12	45
RSR 12N	58
RSR 12W	54.5
RSR 12WN	69.5
RSR 15	55
RSR 15N	73
RSR 15W	67.5
RSR 15WN	86.5

Overall LM Block Length without a Seal

Unit: mm

Model No.	Without seal
RSR 3M	12
RSR 3N	16
RSR 3WM	14.1
RSR 3WN	19.1
RSR 5M	15.5
RSR 5N	18.7
RSR 5WM	20.7
RSR 5WN	26.7
RSR 7M	22
RSR 7N	31.6
RSR 7WM	30
RSR 7WN	39.9
RSR 9KM	27.8
RSR 9N	37.8
RSR 9WV	36
RSR 9WVM	36
RSR 9WN	47.7

Model No.	Without seal
RSR 12VM	31
RSR 12N	43.7
RSR 12WV	41.3
RSR 12WVM	41.3
RSR 12WN	56.3
RSR 15VM	38.9
RSR 15N	56.5
RSR 15WV	51.5
RSR 15WVM	51.5
RSR 15WN	70.5
RSR 20VM	61.5
RSR 20N	81.3

Precautions on Use

QZ Lubricator for THK LM Guides

Handling

- Dropping or hitting this product may damage it. Take much care when handling it.
- Do not clean it with an organic solvent or white kerosene.
- Do not leave it unpacked for a long period of time.
- Do not block the air vent with grease or the like.

Service temperature range

- Be sure the service temperature of this product is between -10°C and $+50^{\circ}\text{C}$. When using it beyond the service temperature range, contact THK.

Use in a special environment

- When using it in a special environment, contact THK.

Precaution on selection

- Be sure the stroke is longer than the overall length of the LM block length attached with QZ Lubricator.

Corrosion prevention of LM Guides

- QZ Lubricator is a lubricating device designed to feed a minimum amount of oil to the ball raceway of LM rails, and does not provide corrosion prevention to the whole LM Guide. When using it in an environment subject to a coolant or the like, we strongly recommend applying grease or other anti-corrosion agent to the mounting base surface and the LM rail end surfaces of the LM Guide as an anti-corrosion measure.