

LM Guide Model HSR

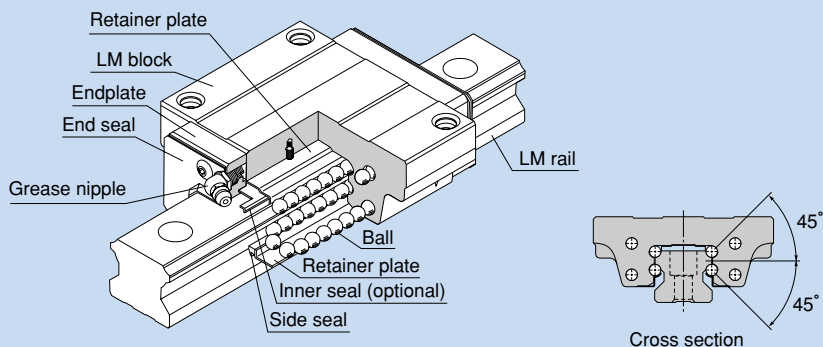

Fig. 1 Structure of Model SHS

● Structure and Features

Balls roll in four rows of raceways precision-ground on an LM rail and an LM block, and end-plates incorporated in the LM block allow the balls to circulate.

Since retainer plates hold the balls, they do not fall off even if the LM rail is pulled out (except models HSR 8, 10 and 12).

Each row of balls is placed at a contact angle of 45° so that the rated loads applied to the LM block are uniform in the four directions (radial, reverse-radial and lateral directions), enabling the LM Guide to be used in all orientations. In addition, the LM block can receive a well-balanced preload, increasing the rigidity in the four directions while maintaining a constant, low friction coefficient. With the low sectional height and the high rigidity design of the LM block, this model achieves highly accurate and stable linear motion.

● 4-way equal load

Each row of balls is placed at a contact angle of 45° so that the rated loads applied to the LM block are uniform in the four directions (radial, reverse-radial and lateral directions), enabling the LM Guide to be used in all orientations and in extensive applications.

● High-rigidity type

Since balls are arranged in four rows in a well-balanced manner, a large preload can be applied and the rigidity in four directions can easily be increased.

● Self-adjustment capability

The self-adjustment capability through front-to-front configuration of THK's unique circular-arc grooves (DF set) enables a mounting error to be absorbed even under a preload, thus to achieve highly accurate, smooth linear motion.

● High durability

Even under a preload or biased load, differential slip of balls does not occur. As a result, smooth motion, high wear resistance, and long-term maintenance of accuracy are achieved.

● Stainless steel type also available

A special type whose LM block, LM rail and balls are made of stainless steel is also available.

● Types and Features

Model HSR-A

The flange of the LM block has tapped holes.

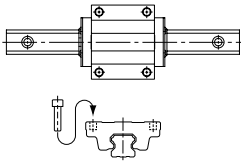

Model HSR-B

The flange of the LM block has through holes. Used in places where the table cannot have through holes for mounting bolts.

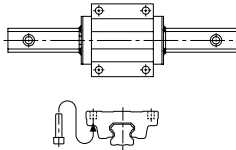

Model HSR-R

Having a smaller LM block width (W) and tapped holes, this model is optimal for compact design.

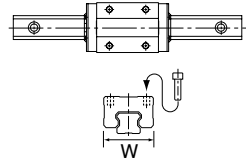

Model HSR-YR

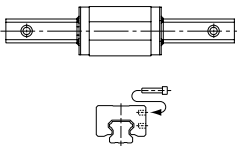

When using two units of LM Guide facing each other, the previous model required much time in machining the table and had difficulty achieving the desired accuracy and adjusting the clearance. Since Model HSR-YR has tapped holes on the side of the LM block, a simpler structure is gained and significant man-hour cutting and accuracy increase can be achieved.

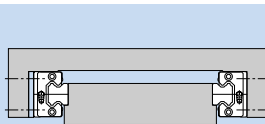

Fig. 2 Conventional Structure

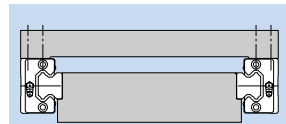
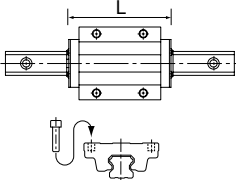

Fig. 3 Mounting Structure for Model HSR-YR

Model HSR-LA

The LM block has the same sectional shape as model HSR-A, but has a longer overall LM block length (L) and a greater rated load.



Model HSR-LB

The LM block has the same sectional shape as model HSR-B, but has a longer overall LM block length (L) and a greater rated load.

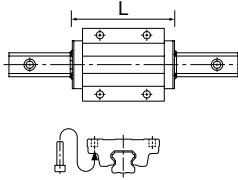

Model HSR-LR

The LM block has the same sectional shape as model HSR-R, but has a longer overall LM block length (L) and a greater rated load.

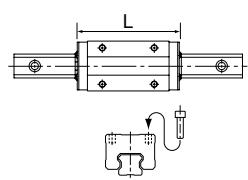

Model HSR-CA

Has six tapped holes on the LM block.

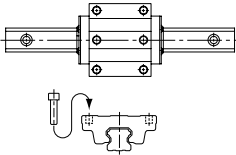

Model HSR-CB

Six-bolt type.
The LM block has six through holes. Used in places where the table cannot have through holes for mounting bolts.

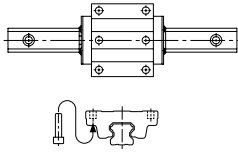

Model HSR-HA

The LM block has the same sectional shape as model HSR-CA, but has a longer overall LM block length (L) and a greater rated load.

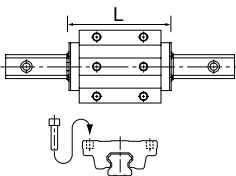

Model HSR-HB

The LM block has the same sectional shape as model HSR-CB, but has a longer overall LM block length (L) and a greater rated load.

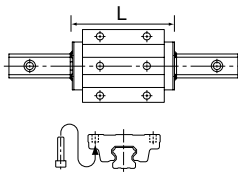

Models HSR 100/120/150 HA/HB/HR

Large types of model HSR that can be used in large-scale machine tools and building structures.

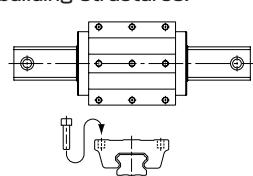

Rated Loads in All Directions

Model HSR is capable of receiving loads in all four directions: radial, reverse-radial and lateral directions.

The basic load ratings are uniform in the four directions (radial, reverse-radial and lateral directions), and their actual values are provided in the dimensional table for HSR.

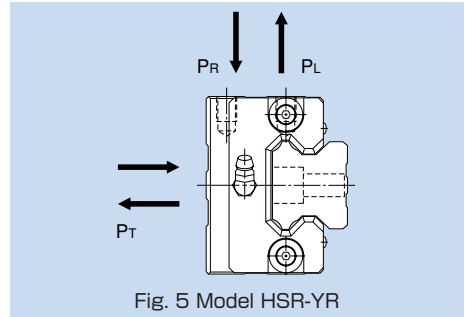
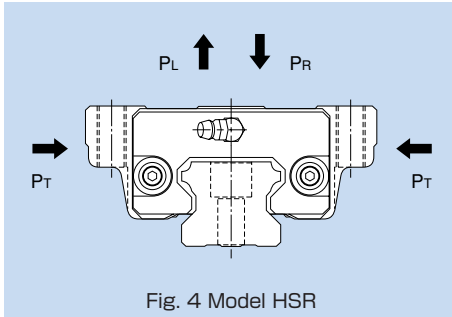

Equivalent Load

When the LM block of model HSR receives loads in the reverse-radial and lateral directions simultaneously, the equivalent load is obtained from the equation below.

$$P_E = P_R (P_L) + P_T$$

where

P_E : Equivalent load (N)

- Radial direction
- Reverse-radial direction
- Lateral direction

P_R : Radial load (N)

P_L : Reverse-radial load (N)

P_T : Lateral load (N)

Options

Dust Prevention Accessories

THK offers various dust prevention accessories for model HSR.

When a dust prevention accessory is required, specify the desired item with the corresponding symbol provided in table 1 (for details of dust prevention accessories, see pages a-24 and a-25).

For supported model numbers for dust prevention accessories and overall LM block length with dust prevention accessories attached (dimension L), see page a-306.

Table 1 Symbols of Dust Prevention Accessories for Model HSR

Symbol	Dust prevention accessory
UU	With end seal
SS	With end seal + side seal
DD	With double seals + side seal
ZZ	With end seal + side seal + metal scraper
KK	With double seals + side seal + metal scraper
LL	With low-resistance end seal
RR	With LL seal + side seal
SSH	With end seal + side seal + LaCS
DDH	With double seals + side seal + LaCS
ZZH	With end seal + side seal + metal scraper + LaCS
KKH	With double seals + side seal + metal scraper + LaCS

Seal resistance value

For the maximum seal resistance value per LM block when a lubricant is applied on seals HSR ... UU, refer to the corresponding value provided in table 2.

Table 2 Maximum Seal Resistance Value of Seals HSR ... UU

Unit: N

Model No.	Seal resistance value
HSR 8	0.5
HSR 10	0.8
HSR 12	1.2
HSR 15	2.0
HSR 20	2.5
HSR 25	3.9
HSR 30	7.8
HSR 35	11.8
HSR 45	19.6
HSR 55	19.6
HSR 65	34.3
HSR 85	34.3

● Dedicated Bellows JH for Model HSR

The table below shows the dimensions of dedicated bellows JH for model HSR. Specify the corresponding model number of the desired bellows from the table.

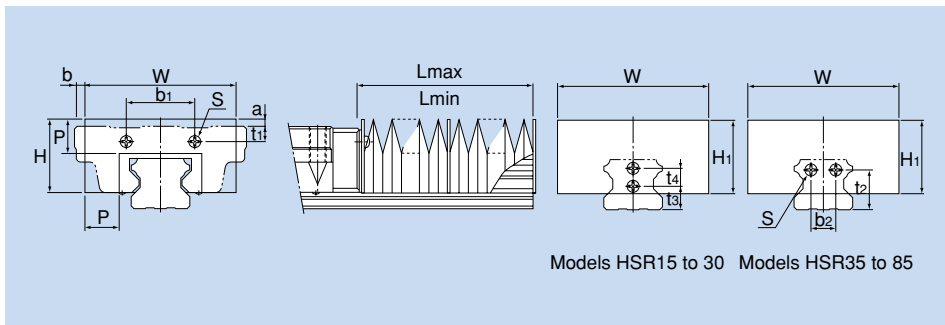

Unit: mm

Model No.	Major dimensions														Supported model			
	W	H	H ₁	P	b ₁	Type A/B t ₁	Type R t ₁	b ₂	t ₂	t ₃	t ₄	Mounting bolt S	Type A/B a	Type R a		Type A/B b	Type R b	($\frac{A}{L_{min}}$) L _{max} L _{min}
JH 15	55	27	30	15	25	2.5	6.5	—	—	10	—	*M4X 8ℓ	7.5	3.5	-4	-10.5	5	HSR 15
JH 20	66	32	35	17	34	5	5	—	—	6	8	M3X 6ℓ	7	7	-1.5	-11	6	HSR 20
JH 25	78	38	38	20	30	7	11	—	—	10	8	M3X 6ℓ	8.5	4.5	-4	-15	7	HSR 25
JH 30	84	42	42	20	40	8	11	—	—	11	10	M4X 8ℓ	7	4	3	-12	7	HSR 30
JH 35	88	43	43	20	40	9	16	14	23	—	—	M4X 8ℓ	4	—	6	-9	7	HSR 35
JH 45	100	51	51	20	58	10	20	20	29	—	—	M5X10ℓ	—	—	10	-7	7	HSR 45
JH 55	108	54	54	20	66	11	21	26	35	—	—	M5X10ℓ	—	—	16	-4	7	HSR 55
JH 65	132	68	68	20	80	19	19	32	42	—	—	M6X12ℓ	—	—	19	-3	7	HSR 65
JH 85	170	88	88	30	105	23	23	44	50	—	—	M6X12ℓ	—	—	22.5	-7	10	HSR 85

Note 1: For model JH15's location marked with "*", mounting bolts are used only on the LM rail side while the LM block side uses M2 × 5 (nominal) tapped pins.

Note 2: When desiring to use the dedicated bellows other than in horizontal mount (i.e., vertical, wall and inverted mount), or when desiring a heat-resistant type of bellows, contact

Note 3: For lubrication when using the dedicated bellows, contact

Note 4: When using the dedicated bellows, the LM block and LM rail need to be machined so that the bellows can be mounted. Be sure to indicate that the dedicated bellows is required when ordering the LM Guide.

Model number coding **JH25-60/420**

1

2

1 Model number ... bellows for HSR25

2 Bellows dimensions (length when compressed / length when extended)

Note: The length of the bellows is calculated as follows.

$$L_{min} = \frac{S}{(A-1)} \quad S: \text{Stroke length (mm)}$$

$$L_{max} = L_{min} \cdot A \quad A: \text{Extension rate}$$

●Dedicated Bellows DH for Model HSR

For models HSR15, 20 and 25, bellows DH, which has the following features, is also available other than the dedicated bellows JH. When desiring bellows DH, specify the corresponding model number from the table below.

Features

- ① Has a width and height smaller than the conventional product so that any part of the bellows does not stick out of the top face of the LM block. The extension rate is equal to or greater than that of the conventional type.
- ② Has an intermediate plate for each crest so that it will not easily lift and the bellows can be used with vertical mount, wall mount and slant mount.
- ③ Operable at high speed, at up to 120 m/min.
- ④ Since a Velcro tape can be used to install the bellows, a regular-size model can be cut to the desired length, or two or more regular-size bellows can be taped together.
- ⑤ Can be installed using screws just as bellows JH.

In this case, a plate (thickness: 1.6 mm) must be placed between the bellows and the LM block. Contact **THK** for details.

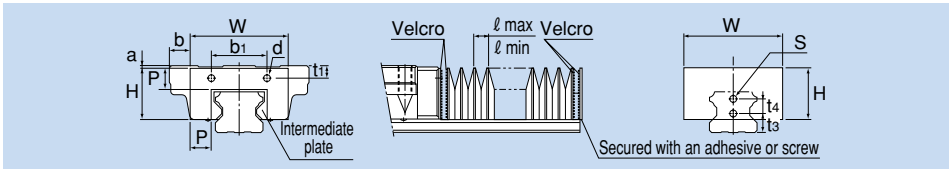

Unit: mm

Model No.	Major dimensions																			Supported model
	W	H	P	b ₁	Type A/B	t ₁ Type R	t ₃	t ₄	d	Type A/B	a Type R	Type A/B	b Type R	ℓ max	ℓ min	Extension rate A	E	Factor k		
DH 15	35	19.5	8.5	25	2.5	6.5	10	—	3.5	0	4	6	-0.5	10	2.5	4	2	1.2	HSR 15	
DH 20	45	25	10	34	5	5	6	8	4	0	0	9	-0.5	13	2.5	5	2	1.3	HSR 20	
DH 25	52	29.5	12	30	7	11	10	8	4	0	4	9	-2	15	3	5	2	1.3	HSR 25	

Note 1: For lubrication when using the dedicated bellows, contact **THK**.

Note 2: When using the dedicated bellows, the LM block and LM rail need to be machined so that the bellows can be mounted. Be sure to indicate that the dedicated bellows is required when ordering the LM Guide.

Model number coding

DH20-50/250

1

2

1 Model number ... bellows for HSR20

2 Bellows dimensions (length when compressed / length when extended)

Note: The maximum length of the bellows itself is calculated as follows.

$$L_{\max}(L_{\min}) = \ell_{\max}(\ell_{\min}) \times 200$$

Example of calculating bellows dimensions:

When the stroke of model SR20 is: $\ell s = 530$ mm

$$L_{\min} = \frac{\ell s}{A-1} = \frac{530}{4} = 132.5 \div 135$$

$$L_{\max} = A \cdot L_{\min} = 5 \times 135 = 675$$

Number of required crests n

$$n = \frac{L_{\max}}{P \cdot k} = \frac{675}{10 \times 1.3} = 51.9 \div 52 \text{ crests}$$

$$L_{\min} = n \cdot \ell_{\min} + E = 52 \times 2.5 + 2 = 132$$

(E indicates the plate thickness of 2)

Therefore, the model number of the required bellows is DH20-132/675.

● Dedicated LM Cover TPH for Model HSR

The tables below show the dimensions of dedicated LM cover TPH for model HSR. Specify the corresponding model number of the desired bellows from the table.

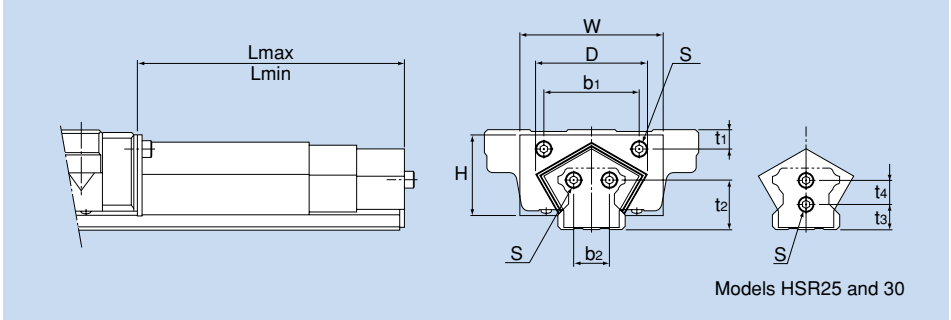

Unit: mm

Model No.	Major dimensions										Supported model
	W	D (max)	H	b ₁	t ₁	b ₂	t ₂	t ₃	t ₄	Mounting bolt S	
TPH 25	55	42	28	30	7	—	—	10	8	M3× 6 ℓ	HSR 25
TPH 30	60	48	34	40	8	—	—	11	10	M4× 8 ℓ	HSR 30
TPH 35	70	55	38	40	9	14	23	—	—	M4× 8 ℓ	HSR 35
TPH 45	90	75	48	58	10	20	29	—	—	M5×10 ℓ	HSR 45
TPH 55	100	88	55	66	11	26	35	—	—	M5×10 ℓ	HSR 55

Unit: mm

Model No.	Stage	L		Stroke
		min	max	
TPH 25	3	200	530	330
	3	150	380	230
	3	100	230	130
TPH 30	3	250	680	430
	3	200	530	330
	3	150	380	230
TPH 35	3	300	830	530
	3	250	680	430
	3	200	530	330
	3	150	380	230
	3	150	380	230

Unit: mm

Model No.	Stage	L		Stroke
		min	max	
TPH 45	3	350	980	630
	3	300	830	530
	3	250	680	430
	3	200	530	330
	3	200	530	330
TPH 55	4	400	1460	1060
	4	350	1330	980
	4	300	1060	760
	4	250	860	610

Note 1: For lubrication when using the dedicated LM cover, contact THK.

Note 2: When using the dedicated LM cover, the LM block and LM rail need to be machined so that the bellows can be mounted. Be sure to indicate that the dedicated bellows is required when ordering the LM Guide.

Model number coding **TPH55-400/1460**

1 **2** **3**

- 1 Model number ... LM cover for HSR55
- 2 Lmin(cover length when contracted)
- 3 Lmax(cover length when extended)

● Dedicated Cap C for LM Rail Mounting Holes

If any of the LM rail mounting holes of an LM Guide is filled with cutting chips or foreign matter, they may enter the LM block structure. Entrance of such foreign matter can be prevented by covering each LM rail mounting hole with the dedicated cap so that the top of the mounting holes is on the same level as the LM rail top face.

Since the dedicated cap C for LM rail mounting holes uses a special synthetic resin with high oil resistance and high wear resistance, it is highly durable.

When placing an order, specify the desired cap type with the corresponding cap number indicated in table 3.

For the procedure for mounting the cap, see page a-22.

Table 3 Major Dimensions of Dedicated Cap C

Model No.	Cap C model No.	Bolt used	Major dimensions mm	
			D	H
HSR 12	C 3	M 3	6.3	1.2
HSR 15	C 4	M 4	7.8	1.0
HSR 20	C 5	M 5	9.8	2.4
HSR 25	C 6	M 6	11.4	2.7
HSR 30	C 8	M 8	14.4	3.7
HSR 35	C 8	M 8	14.4	3.7
HSR 45	C12	M12	20.5	4.7
HSR 55	C14	M14	23.5	5.7
HSR 65	C16	M16	26.5	5.7
HSR 85	C22	M22	35.5	5.7

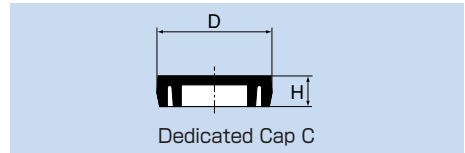

QZ Lubricator™

When QZ Lubricator is required, specify the desired type with the corresponding symbol indicated in table 4 (for details of QZ Lubricator, see pages a-19 and a-20).

For supported LM Guide model numbers for QZ Lubricator and overall LM block length with QZ Lubricator attached (dimension L), see page a-307.

Table 4 Parts Symbols for Model HSR with QZ Lubricator Attached

Symbol	Dust prevention accessories for LM Guide with QZ Lubricator attached
QZUU	With end seal
QZSS	With end seal + side seal
QZDD	With double seals + side seal
QZZZ	With end seal + side seal + metal scraper + QZ
QZKK	With double seals + side seal + metal scraper + QZ
QZSSHH	With end seal + side seal + LaCS + QZ
QZDDHH	With double seals + side seal + LaCS + QZ
QZZZHH	With end seal + side seal + metal scraper + LaCS + QZ
QZKKHH	With double seals + side seal + metal scraper + LaCS + QZ

Stopper

With miniature LM Guide models HSR8, 10 and 12, balls will fall off if the LM block is removed from the LM rail. To prevent the LM block from being pulled out, end pieces are mounted before shipment. If removing the stopper when using the LM Guide, be sure that the LM block will not overrun.

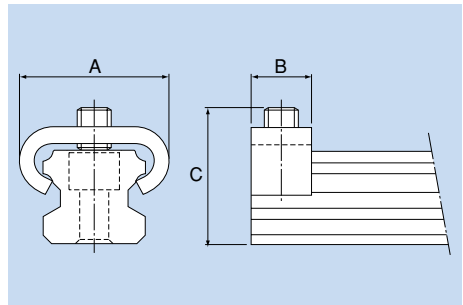

Unit: mm

Model No.	A	B	C
HSR 8	12.5	6	10
HSR 10	15	6	11
HSR 12	18.5	7	16

Semi-standard Greasing Hole

For model HSR, a semi-standard greasing hole is available. Specify the appropriate model number according to the application.

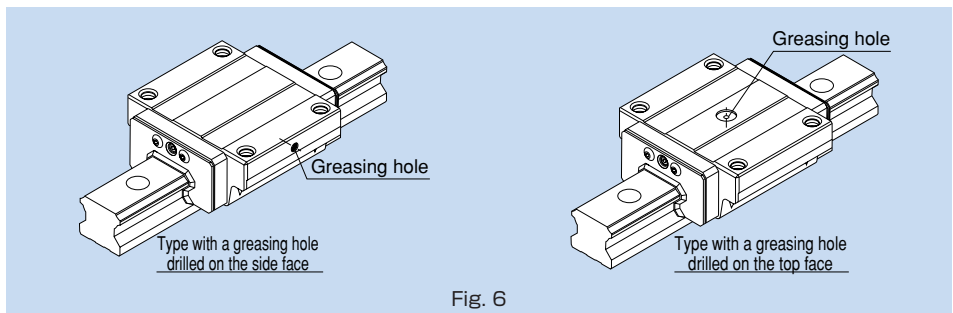

Fig. 6

Contact THK for details.

Tapped LM Rail Type of Model HSR

The model HSR variations include a type with its LM rail bottom tapped. This type is useful when desiring to mount the LM Guide from the bottom of the base and when desiring to increase the dust prevention effect.

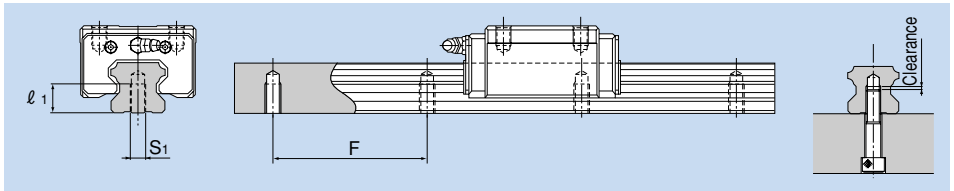
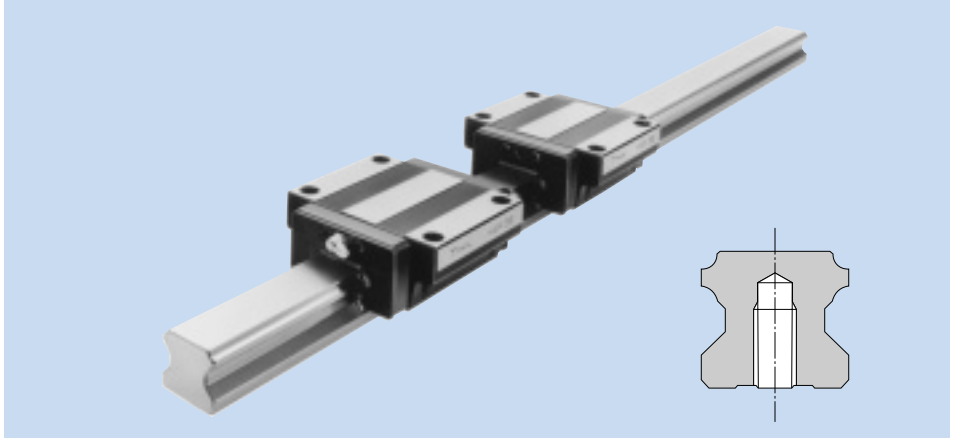

Table 5 Dimensions of the LM Rail Tap

Unit: mm

- ① Determine the bolt length so that a clearance of 2 to 5 mm is secured between the bolt end and the bottom of the tap (effective tap depth) (see figure above).
- ② A tapped LM rail type is available also for model HSR-YR.
- ③ For standard pitches of the taps, see table 6 on page a-289.

Model No.	S ₁	Effective tap depth l_1
HSR 15	M5	8
HSR 20	M6	10
HSR 25	M6	12
HSR 30	M8	15
HSR 35	M8	17
HSR 45	M12	24
HSR 55	M14	24
HSR 65	M20	30

Model number coding **HSR30 A2UU+1000LH K**

1

1 Symbol for tapped LM rail type

Standard Length and Maximum Length of the LM Rail

Table 6 shows the standard lengths and the maximum lengths of model HSR variations. If the maximum length of the desired LM rail exceeds them, connected rails will be used. Contact THK for details.

For the G dimension when a special length is required, we recommend selecting the corresponding G value from the table. The longer the G dimension is, the less stable the G area may become after installation, thus causing an adverse impact to accuracy.

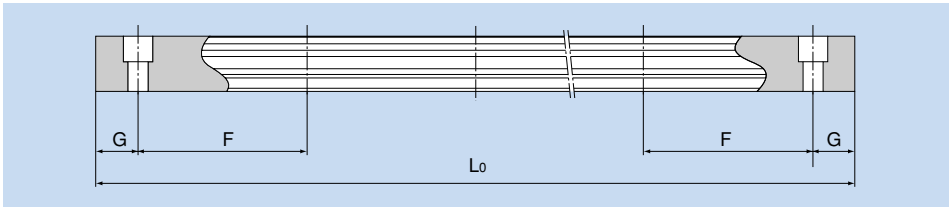

Table 6 Standard Length and Maximum Length of the LM Rail for Model HSR Unit: mm

Model No.	HSR 8	HSR 10	HSR 12	HSR 15	HSR 20	HSR 25	HSR 30	HSR 35	HSR 45	HSR 55	HSR 65	HSR 85	HSR 100	HSR 120	HSR 150
Standard LM rail length (L ₀)	35	45	70	160	220	220	280	280	570	780	1270	1530	1340	1470	1600
	55	70	110	220	280	280	360	360	675	900	1570	1890	1760	1930	2100
	75	95	150	280	340	340	440	440	780	1020	2020	2250	2180	2390	2350
	95	120	190	340	400	400	520	520	885	1140	2620	2610	2600		
	115	145	230	400	460	460	600	600	990	1260					
	135	170	270	460	520	520	680	680	1095	1380					
	155	195	310	520	580	580	760	760	1200	1500					
	175	220	350	580	640	640	840	840	1305	1620					
	195	245	390	640	700	700	920	920	1410	1740					
	215	270	430	700	760	760	1000	1000	1515	1860					
	235	295	470	760	820	820	1080	1080	1620	1980					
	255	320	510	820	940	940	1160	1160	1725	2100					
	275	345	550	940	1000	1000	1240	1240	1830	2220					
		370	590	1000	1060	1060	1320	1320	1935	2340					
		395	630	1060	1120	1120	1400	1400	2040	2460					
		420	670	1120	1180	1180	1480	1480	2145	2580					
		445		1180	1240	1240	1560	1560	2250	2700					
		470		1240	1360	1300	1640	1640	2355	2820					
				1360	1480	1360	1720	1720	2460	2940					
				1480	1600	1420	1800	1800	2565	3060					
			1600	1720	1480	1880	1880	2670							
				1840	1540	1960	1960	2775							
				1960	1600	2040	2040	2880							
				2080	1720	2200	2200	2985							
				2200	1840	2360	2360	3090							
					1960	2520	2520								
					2080	2680	2680								
					2200	2840	2840								
					2320	3000	3000								
					2440										
Standard pitch F	20	25	40	60	60	60	80	80	105	120	150	180	210	230	250
G	7.5	10	15	20	20	20	20	20	22.5	30	35	45	40	45	50
Max length (275)	(470)	(670)	(2500 (1240)	(3000 (1480)	(3000 (2020)	(3000 (2520)	(3090)	(3060)	3000	3000	3000	3000	3000	3000	3000

Note 1: The maximum length varies with accuracy grades. Contact THK for details.

Note 2: If connected rails are not allowed and a greater length than the maximum values above is required, contact THK.

Note 3: The figures in the parentheses indicate the maximum lengths of stainless steel made models.

Models HSR-A | HSR-AM
Models HSR-LA | HSR-LAM

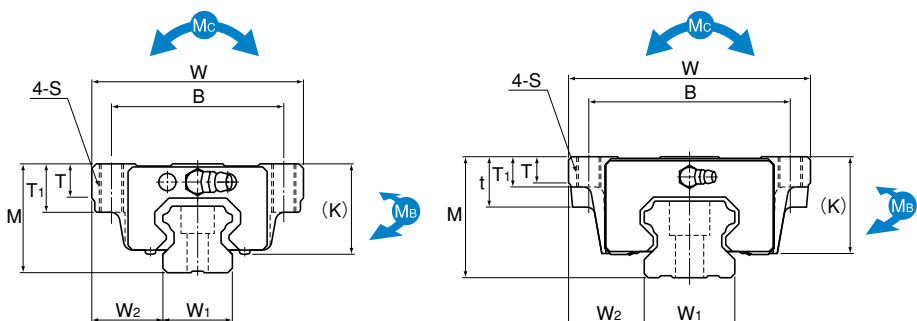

Models HSR15 to 35A/LA/AM/LAM

Models HSR45 to 85A/LA

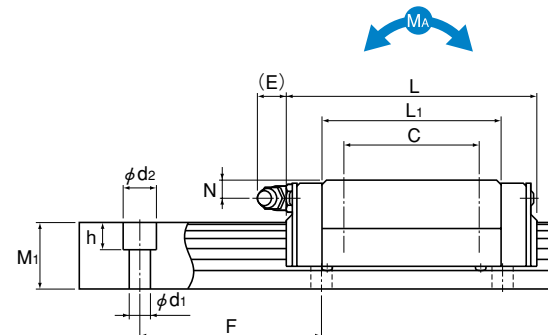

Unit: mm

Model No.	External dimensions			LM block dimensions										Grease nipple	LM rail dimensions				Basic load rating		Static permissible moment kN-m*				Mass		
	Height	Width	Length	B	C	S	L ₁	t	T	T ₁	K	N	E		Width W ₁ ±0.05	W ₂	Height M ₁	Pitch F	d ₁ × d ₂ × h	C	C ₀	M _A 1 block	M _A 2 blocks in close contact	M _B 1 block	M _B 2 blocks in close contact	M _C 1 block	LM block kg
HSR 15A HSR 15AM	24	47	56.6	38	30	M5	38.8	—	7	11	19.3	4.3	5.5	15	16	15	60	4.5×7.5×5.3	8.33	13.5	0.0805	0.457	0.0805	0.457	0.0844	0.2	1.5
HSR 20A HSR 20AM	30	63	74	53	40	M6	50.8	—	10	9.5	26	5	12	20	21.5	18	60	6×9.5×8.5	13.8	23.8	0.19	1.04	0.19	1.04	0.201	0.35	2.3
HSR 20LA HSR 20LAM	30	63	90	53	40	M6	66.8	—	10	9.5	26	5	12	20	21.5	18	60	6×9.5×8.5	21.3	31.8	0.323	1.66	0.323	1.66	0.27	0.47	2.3
HSR 25A HSR 25AM	36	70	83.1	57	45	M8	59.5	—	11	16	30.5	6	12	23	23.5	22	60	7×11×9	19.9	34.4	0.307	1.71	0.307	1.71	0.344	0.59	3.3
HSR 25LA HSR 25LAM	36	70	102.2	57	45	M8	78.6	—	11	16	30.5	6	12	23	23.5	22	60	7×11×9	27.2	45.9	0.529	2.74	0.529	2.74	0.459	0.75	3.3
HSR 30A HSR 30AM	42	90	98	72	52	M10	70.4	—	9	18	35	7	12	28	31	26	80	9×14×12	28	46.8	0.524	2.7	0.524	2.7	0.562	1.1	4.8
HSR 30LA HSR 30LAM	42	90	120.6	72	52	M10	93	—	9	18	35	7	12	28	31	26	80	9×14×12	37.3	62.5	0.889	4.37	0.889	4.37	0.751	1.3	4.8
HSR 35A HSR 35AM	48	100	109.4	82	62	M10	80.4	—	12	21	40.5	8	12	34	33	29	80	9×14×12	37.3	61.1	0.782	3.93	0.782	3.93	0.905	1.6	6.6
HSR 35LA HSR 35LAM	48	100	134.8	82	62	M10	105.8	—	12	21	40.5	8	12	34	33	29	80	9×14×12	50.2	81.5	1.32	6.35	1.32	6.35	1.2	2	6.6
HSR 45A HSR 45LA	60	120	139 170.8	100	80	M12	98 129.8	25	13	15	50	10	16	45	37.5	38	105	14×20×17	60 80.4	95.6 127	1.42 2.44	7.92 12.6	1.42 2.44	7.92 12.6	1.83 2.43	2.8 3.3	11
HSR 55A HSR 55LA	70	140	163 201.1	116	95	M14	118 156.1	29	13.5	17	57	11	16	53	43.5	44	120	16×23×20	88.5 119	137 183	2.45 4.22	13.2 21.3	2.45 4.22	13.2 21.3	3.2 4.28	4.5 5.7	15.1
HSR 65A HSR 65LA	90	170	186 245.5	142	110	M16	147 206.5	37	21.5	23	76	19	16	63	53.5	53	150	18×26×22	141 192	215 286	4.8 8.72	23.5 40.5	4.8 8.72	23.5 40.5	5.82 7.7	8.5 10.7	22.5
HSR 85A HSR 85LA	110	215	245.6 303	185	140	M20	178.6 236	55	28	30	94	23	16	85	65	65	180	24×35×28	210 282	310 412	8.31 14.2	45.6 72.5	8.31 14.2	45.6 72.5	11 14.7	17 23	35.2

Model number coding **HSR25 A 2 QZ UU C0 M +1200L P M- II**

1 2 3 4 5 6 7 8 9 10 11

- 1 Model number
- 2 Type of LM block
- 3 No. of LM blocks used on the same rail
- 4 With QZ Lubricator
- 5 Dust prevention accessory symbol (see page a-282)
- 6 Radial clearance symbol (see page a-33)
- 7 LM block is made of stainless steel
- 8 LM rail length (in mm)
- 9 Accuracy symbol (see page a-38)
- 10 LM rail is made of stainless steel
- 11 No. of rails used on the same plane

Note This model number indicates that a single-rail unit constitutes one set (i.e., required number of sets when 2 rails are used in parallel is 2 at a minimum). Those models equipped with QZ Lubricator cannot have a grease nipple.

Note Symbol M indicates that stainless steel is used in the LM block, LM rail and balls. Those models marked with this symbol are therefore highly resistant to corrosion and environment.

Static permissible moment* 1 block: static permissible moment value with 1 LM block
2 blocks: static permissible moment value with 2 blocks closely contacting with each other

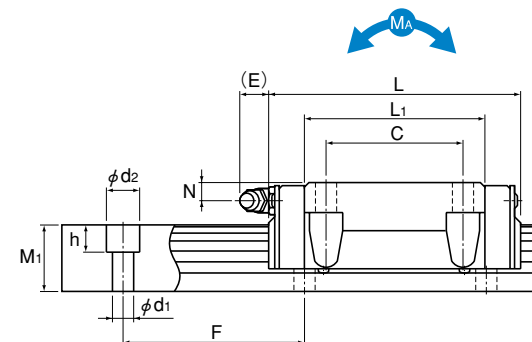
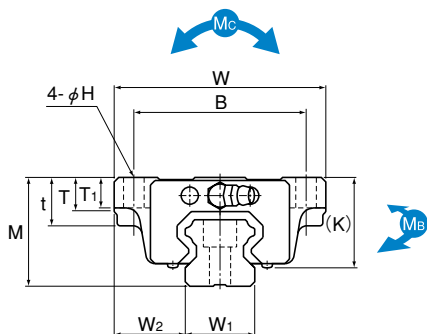

Unit: mm

Model No.	External dimensions			LM block dimensions										Grease nipple	LM rail dimensions				Basic load rating		Static permissible moment kN-m*				Mass		
	Height	Width	Length	B	C	H	L ₁	t	T	T ₁	K	N	E		Width W ₁ ±0.05	Width W ₂	Height M ₁	Pitch F	d ₁ × d ₂ × h	C	C ₀	M _A 1 block	M _A 2 blocks in close contact	M _B 1 block	M _B 2 blocks in close contact	M _C 1 block	LM block kg
HSR 15B HSR 15BM	24	47	56.6	38	30	4.5	38.8	11	7	7	19.3	4.3	5.5	15	16	15	60	4.5×7.5×5.3	8.33	13.5	0.0805	0.457	0.0805	0.457	0.0844	0.2	1.5
HSR 20B HSR 20BM	30	63	74	53	40	6	50.8	10	9.5	10	26	5	12	20	21.5	18	60	6×9.5×8.5	13.8	23.8	0.19	1.04	0.19	1.04	0.201	0.35	2.3
HSR 20LB HSR 20LBM	30	63	90	53	40	6	66.8	10	9.5	10	26	5	12	20	21.5	18	60	6×9.5×8.5	21.3	31.8	0.323	1.66	0.323	1.66	0.27	0.47	2.3
HSR 25B HSR 25BM	36	70	83.1	57	45	7	59.5	16	11	10	30.5	6	12	23	23.5	22	60	7×11×9	19.9	34.4	0.307	1.71	0.307	1.71	0.344	0.59	3.3
HSR 25LB HSR 25LBM	36	70	102.2	57	45	7	78.6	16	11	10	30.5	6	12	23	23.5	22	60	7×11×9	27.2	45.9	0.529	2.74	0.529	2.74	0.459	0.75	3.3
HSR 30B HSR 30BM	42	90	98	72	52	9	70.4	18	9	10	35	7	12	28	31	26	80	9×14×12	28	46.8	0.524	2.7	0.524	2.7	0.562	1.1	4.8
HSR 30LB HSR 30LBM	42	90	120.6	72	52	9	93	18	9	10	35	7	12	28	31	26	80	9×14×12	37.3	62.5	0.889	4.37	0.889	4.37	0.751	1.3	4.8
HSR 35B HSR 35BM	48	100	109.4	82	62	9	80.4	21	12	13	40.5	8	12	34	33	29	80	9×14×12	37.3	61.1	0.782	3.93	0.782	3.93	0.905	1.6	6.6
HSR 35LB HSR 35LBM	48	100	134.8	82	62	9	105.8	21	12	13	40.5	8	12	34	33	29	80	9×14×12	50.2	81.5	1.32	6.35	1.32	6.35	1.2	2	6.6
HSR 45B HSR 45LB	60	120	139 170.8	100	80	11	98 129.8	25	13	15	50	10	16	45	37.5	38	105	14×20×17	60 80.4	95.6 127	1.42 2.44	7.92 12.6	1.42 2.44	7.92 12.6	1.83 2.43	2.8 3.3	11
HSR 55B HSR 55LB	70	140	163 201.1	116	95	14	118 156.1	29	13.5	17	57	11	16	53	43.5	44	120	16×23×20	88.5 119	137 183	2.45 4.22	13.2 21.3	2.45 4.22	13.2 21.3	3.2 4.28	4.5 5.7	15.1
HSR 65B HSR 65LB	90	170	186 245.5	142	110	16	147 206.5	37	21.5	23	76	19	16	63	53.5	53	150	18×26×22	141 192	215 286	4.8 8.72	23.5 40.5	4.8 8.72	23.5 40.5	5.82 7.7	8.5 10.7	22.5
HSR 85B HSR 85LB	110	215	245.6 303	185	140	18	178.6 236	55	28	30	94	23	16	85	65	65	180	24×35×28	210 282	310 412	8.31 14.2	45.6 72.5	8.31 14.2	45.6 72.5	11 14.7	17 23	35.2

Model number coding **HSR25 B 2 QZ UU C0 M +1200L P M- II**

1 2 3 4 5 6 7 8 9 10 11

- 1 Model number
- 2 Type of LM block
- 3 No. of LM blocks used on the same rail
- 4 With QZ Lubricator
- 5 Dust prevention accessory symbol (see page a-282)
- 6 Radial clearance symbol (see page a-33)
- 7 LM block is made of stainless steel
- 8 LM rail length (in mm)
- 9 Accuracy symbol (see page a-38)
- 10 LM rail is made of stainless steel
- 11 No. of rails used on the same plane

Note This model number indicates that a single-rail unit constitutes one set (i.e., required number of sets when 2 rails are used in parallel is 2 at a minimum). Those models equipped with QZ Lubricator cannot have a grease nipple.

Note Symbol M indicates that stainless steel is used in the LM block, LM rail and balls. Those models marked with this symbol are therefore highly resistant to corrosion and environment.

Static permissible moment* 1 block: static permissible moment value with 1 LM block
2 blocks: static permissible moment value with 2 blocks closely contacting with each other

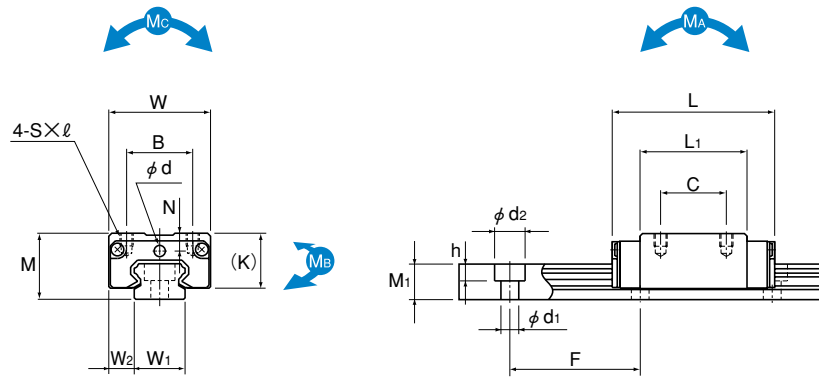

Models HSR8RM and 10RM

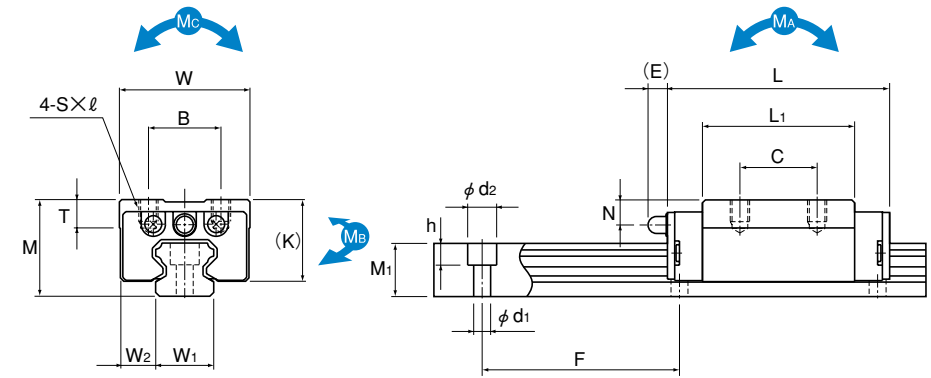

Model HSR12RM

Unit: mm

Model No.	External dimensions			LM block dimensions										LM rail dimensions				Basic load rating		Static permissible moment kN-m*					Mass		
	Height M	Width W	Length L	B	C	S × ℓ	L ₁	T	K	N	E	Greasing hole d	Grease nipple	Width W ₁ ±0.05	W ₂	Height M ₁	Pitch F	d ₁ × d ₂ × h	C kN	C ₀ kN	M _A 1 block	M _B 2 blocks in close contact	M _B 1 block	M _B 2 blocks in close contact	M _C 1 block	LM block kg	LM rail kg/m
HSR 8RM	11	16	24	10	10	M2×2.5	15	—	8.9	2.6	—	2.2	—	8	4	6	20	2.4×4.2×2.3	1.08	2.16	0.00492	0.0319	0.00492	0.0319	0.00727	0.012	0.3
HSR 10RM	13	20	31	13	12	M2.6×2.5	20.1	—	10.8	3.5	—	2.5	—	10	5	7	25	3.5×6×3.3	1.96	3.82	0.0123	0.0716	0.0123	0.0716	0.0162	0.025	0.45
HSR 12RM	20	27	45	15	15	M4×4.5	30.5	6	16.9	5.2	4	—	PB107	12	7.5	11	40	3.5×6×4.5	4.7	8.53	0.0409	0.228	0.0409	0.228	0.0445	0.08	0.83

Note Stainless steel is used in the LM block, LM rail and balls. Those models marked with this symbol are therefore highly resistant to corrosion and environment.

Static permissible moment* 1 block: static permissible moment value with 1 LM block
2 blocks: static permissible moment value with 2 blocks closely contacting with each other

Model number coding

HSR12 R 2 UU C1 M +670L H M- II

1 2 3 4 5 6 7 8 9 10

- 1 Model number
- 2 Type of LM block
- 3 No. of LM blocks used on the same rail
- 4 Dust prevention accessory symbol (see page a-282)
- 5 Radial clearance symbol (see page a-33)
- 6 LM block is made of stainless steel
- 7 LM rail length (in mm)
- 8 Accuracy symbol (see page a-38)
- 9 LM rail is made of stainless steel
- 10 No. of rails used on the same plane

Note This model number indicates that a single-rail unit constitutes one set (i.e., required number of sets when 2 rails are used in parallel is 2 at a minimum).

Models HSR-R | HSR-RM
Models HSR-LR | HSR-LRM

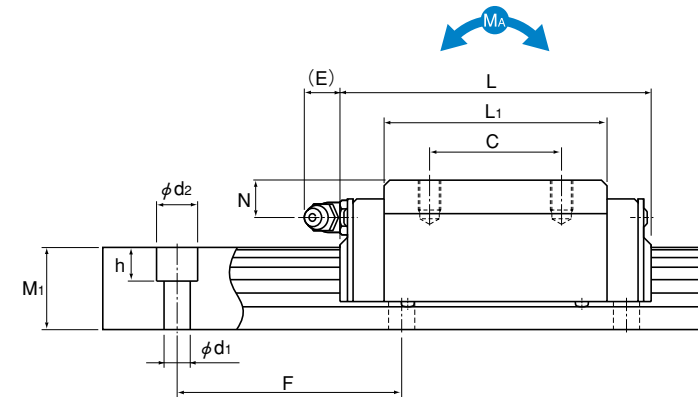
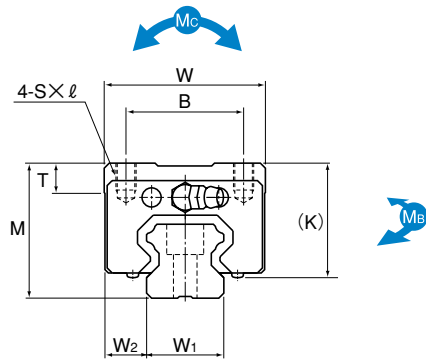

Unit: mm

Model No.	External dimensions			LM block dimensions								LM rail dimensions				Basic load rating		Static permissible moment kN-m*					Mass			
	Height M	Width W	Length L	B	C	S x l	L ₁	T	K	N	E	Grease nipple	Width W ₁ ±0.05	W ₂	Height M ₁	Pitch F	d ₁ x d ₂ x h	C kN	C ₀ kN	M _A 1 block	M _B 2 blocks in close contact	M _B 1 block	M _B 2 blocks in close contact	M _C 1 block	LM block kg	LM rail kg/m
HSR 15R HSR 15RM	28	34	56.6	26	26	M4x5	38.8	6	23.3	8.3	5.5	PB1021B	15	9.5	15	60	4.5x7.5x5.3	8.33	13.5	0.0805	0.457	0.0805	0.457	0.0844	0.18	1.5
HSR 20R HSR 20RM	30	44	74	32	36	M5x6	50.8	8	26	5	12	B-M6F	20	12	18	60	6x9.5x8.5	13.8	23.8	0.19	1.04	0.19	1.04	0.201	0.25	2.3
HSR 20LR HSR 20LRM	30	44	90	32	50	M5x6	66.8	8	26	5	12	B-M6F	20	12	18	60	6x9.5x8.5	21.3	31.8	0.323	1.66	0.323	1.66	0.27	0.35	2.3
HSR 25R HSR 25RM	40	48	83.1	35	35	M6x8	59.5	9	34.5	10	12	B-M6F	23	12.5	22	60	7x11x9	19.9	34.4	0.307	1.71	0.307	1.71	0.344	0.54	3.3
HSR 25LR HSR 25LRM	40	48	102.2	35	50	M6x8	78.6	9	34.5	10	12	B-M6F	23	12.5	22	60	7x11x9	27.2	45.9	0.529	2.74	0.529	2.74	0.459	0.67	3.3
HSR 30R HSR 30RM	45	60	98	40	40	M8x10	70.4	9	38	10	12	B-M6F	28	16	26	80	9x14x12	28	46.8	0.524	2.7	0.524	2.7	0.562	0.9	4.8
HSR 30LR HSR 30LRM	45	60	120.6	40	60	M8x10	93	9	38	10	12	B-M6F	28	16	26	80	9x14x12	37.3	62.5	0.889	4.37	0.889	4.37	0.751	1.1	4.8
HSR 35R HSR 35RM	55	70	109.4	50	50	M8x12	80.4	11.7	47.5	15	12	B-M6F	34	18	29	80	9x14x12	37.3	61.1	0.782	3.93	0.782	3.93	0.905	1.5	6.6
HSR 35LR HSR 35LRM	55	70	134.8	50	72	M8x12	105.8	11.7	47.5	15	12	B-M6F	34	18	29	80	9x14x12	50.2	81.5	1.32	6.35	1.32	6.35	1.2	2	6.6
HSR 45R HSR 45LR	70	86	139 170.8	60	60 80	M10x17	98 129.8	15	60	20	16	B-PT1/8	45	20.5	38	105	14x20x17	60 80.4	95.6 127	1.42 2.44	7.92 12.6	1.42 2.44	7.92 12.6	1.83 2.43	2.6 3.1	11
HSR 55R HSR 55LR	80	100	163 201.1	75	75 95	M12x18	118 156.1	20.5	67	21	16	B-PT1/8	53	23.5	44	120	16x23x20	88.5 119	137 183	2.45 4.22	13.2 21.3	2.45 4.22	13.2 21.3	3.2 4.28	4.3 5.4	15.1
HSR 65R HSR 65LR	90	126	186 245.5	76	70 120	M16x20	147 206.5	23	76	19	16	B-PT1/8	63	31.5	53	150	18x26x22	141 192	215 286	4.8 8.72	23.5 40.5	4.8 8.72	23.5 40.5	5.82 7.7	7.3 9.3	22.5
HSR 85R HSR 85LR	110	156	245.6 303	100	80 140	M18x25	178.6 236	29	94	23	16	B-PT1/8	85	35.5	65	180	24x35x28	210 282	310 412	8.31 14.2	45.6 72.5	8.31 14.2	45.6 72.5	11 14.7	13 16	35.2

Model number coding **HSR35 R 2 QZ SS C0 M +1400L P M- II**

1 2 3 4 5 6 7 8 9 10 11

- 1 Model number
- 2 Type of LM block
- 3 No. of LM blocks used on the same rail
- 4 With QZ Lubricator
- 5 Dust prevention accessory symbol (see page a-282)
- 6 Radial clearance symbol (see page a-33)
- 7 LM block is made of stainless steel
- 8 LM rail length (in mm)
- 9 Accuracy symbol (see page a-38)
- 10 LM rail is made of stainless steel
- 11 No. of rails used on the same plane

Note This model number indicates that a single-rail unit constitutes one set (i.e., required number of sets when 2 rails are used in parallel is 2 at a minimum). Those models equipped with QZ Lubricator cannot have a grease nipple.

Note Symbol M indicates that stainless steel is used in the LM block, LM rail and balls. Those models marked with this symbol are therefore highly resistant to corrosion and environment.

Static permissible moment* 1 block: static permissible moment value with 1 LM block
2 blocks: static permissible moment value with 2 blocks closely contacting with each other

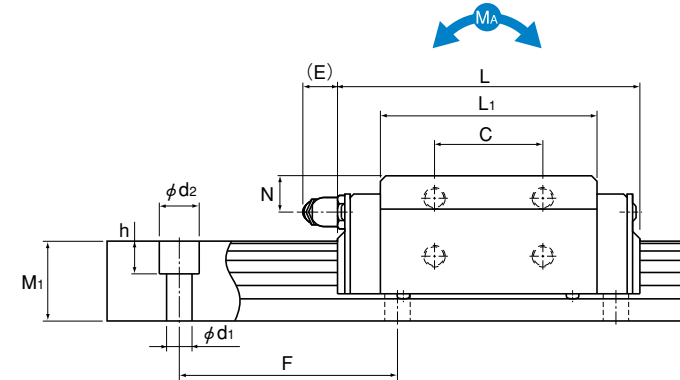
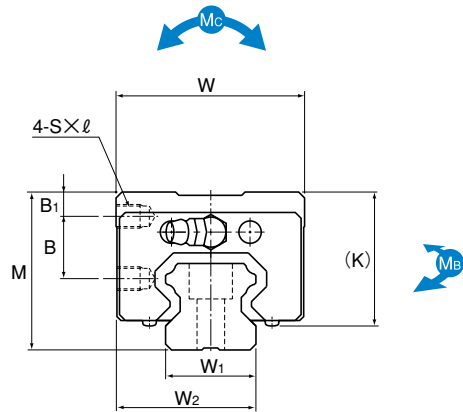

Unit: mm

Model No.	External dimensions			LM block dimensions								LM rail dimensions				Basic load rating		Static permissible moment kN-m*					Mass			
	Height M	Width W	Length L	B ₁	B	C	S × l	L ₁	K	N	E	Grease nipple	Width W ₁ ±0.05	W ₂	Height M ₁	Pitch F	d ₁ × d ₂ × h	C kN	C ₀ kN	M _A 1 block	M _B 2 blocks in close contact	M _B 1 block	M _B 2 blocks in close contact	M _C 1 block	LM block kg	LM rail kg/m
HSR 15YR HSR 15YRM	28	33.5	56.6	4.3	11.5	18	M4 × 5	38.8	23.3	8.3	5.5	PB1021B	15	24	15	60	4.5 × 7.5 × 5.3	8.33	13.5	0.0805	0.457	0.0805	0.457	0.0844	0.18	1.5
HSR 20YR HSR 20YRM	30	43.5	74	4	11.5	25	M5 × 6	50.8	26	5	12	B-M6F	20	31.5	18	60	6 × 9.5 × 8.5	13.8	23.8	0.19	1.04	0.19	1.04	0.201	0.25	2.3
HSR 25YR HSR 25YRM	40	47.5	83.1	6	16	30	M6 × 6	59.5	34.5	10	12	B-M6F	23	35	22	60	7 × 11 × 9	19.9	34.4	0.307	1.71	0.307	1.71	0.344	0.54	3.3
HSR 30YR HSR 30YRM	45	59.5	98	8	16	40	M6 × 9	70.4	38	10	12	B-M6F	28	43.5	26	80	9 × 14 × 12	28	46.8	0.524	2.7	0.524	2.7	0.562	0.9	4.8
HSR 35YR HSR 35YRM	55	69.5	109.4	8	23	43	M8 × 10	80.4	47	15	12	B-M6F	34	51.5	29	80	9 × 14 × 12	37.3	61.1	0.782	3.93	0.782	3.93	0.905	1.5	6.6
HSR 45YR	70	85.5	139	10	30	55	M10 × 14	98	60	20	16	B-PT1/8	45	65	38	105	14 × 20 × 17	60	95.6	1.42	7.92	1.42	7.92	1.83	2.6	11
HSR 55YR	80	99.5	163	12	32	70	M12 × 15	118	67	21	16	B-PT1/8	53	76	44	120	16 × 23 × 20	88.5	137	2.45	13.2	2.45	13.2	3.2	4.3	15.1
HSR 65YR	90	124.5	186	12	35	85	M16 × 22	147	76	19	16	B-PT1/8	63	93	53	150	18 × 26 × 22	141	215	4.8	23.5	4.8	23.5	5.82	7.3	22.5

Note Symbol M indicates that stainless steel is used in the LM block, LM rail and balls. Those models marked with this symbol are therefore highly resistant to corrosion and environment.

Static permissible moment* 1 block: static permissible moment value with 1 LM block
2 blocks: static permissible moment value with 2 blocks closely contacting with each other

Model number coding HSR25 YR 2 UU C0 M +1200L P M- II

1 2 3 4 5 6 7 8 9 10

- 1 Model number
- 2 Type of LM block
- 3 No. of LM blocks used on the same rail
- 4 Dust prevention accessory symbol (see page a-282)
- 5 Radial clearance symbol (see page a-33)
- 6 LM block is made of stainless steel
- 7 LM rail length (in mm)
- 8 Accuracy symbol (see page a-38)
- 9 LM rail is made of stainless steel
- 10 No. of rails used on the same plane

Note This model number indicates that a single-rail unit constitutes one set (i.e., required number of sets when 2 rails are used in parallel is 2 at a minimum).

Models HSR-CA | HSR-CAM
Models HSR-HA | HSR-HAM

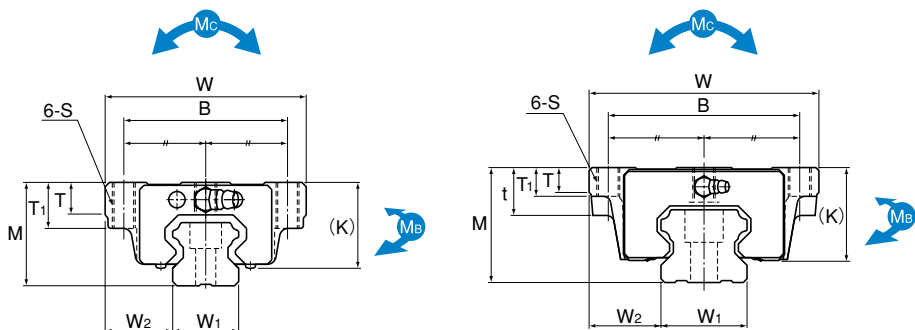

Models HSR20 to 35CA/HA/CAM/HAM

Models HSR45 to 85CA/HA

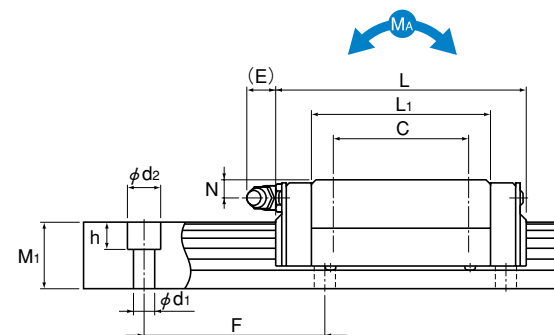

Unit: mm

Model No.	External dimensions			LM block dimensions										Grease nipple	LM rail dimensions				Basic load rating		Static permissible moment kN-m*					Mass	
	Height M	Width W	Length L	B	C	S	L ₁	t	T	T ₁	K	N	E		Width W ₁ ±0.05	W ₂	Height M ₁	Pitch F	d ₁ × d ₂ × h	C	C ₀	M _A 1 block	M _B 2 blocks in close contact 1 block	M _B 2 blocks in close contact 2 blocks	M _C 1 block	LM block kg	LM rail kg/m
HSR 20CA HSR 20CAM	30	63	74	53	40	M6	50.8	—	9.5	10	26	5	12	20	21.5	18	60	6×9.5×8.5	13.8	23.8	0.19	1.04	0.19	1.04	0.201	0.35	2.3
HSR 20HA HSR 20HAM	30	63	90	53	40	M6	66.8	—	9.5	10	26	5	12	20	21.5	18	60	6×9.5×8.5	21.3	31.8	0.323	1.66	0.323	1.66	0.27	0.47	2.3
HSR 25CA HSR 25CAM	36	70	83.1	57	45	M8	59.5	—	11	16	30.5	6	12	23	23.5	22	60	7×11×9	19.9	34.4	0.307	1.71	0.307	1.71	0.344	0.59	3.3
HSR 25HA HSR 25HAM	36	70	102.2	57	45	M8	78.6	—	11	16	30.5	6	12	23	23.5	22	60	7×11×9	27.2	45.9	0.529	2.74	0.529	2.74	0.459	0.75	3.3
HSR 30CA HSR 30CAM	42	90	98	72	52	M10	70.4	—	9	18	35	7	12	28	31	26	80	9×14×12	28	46.8	0.524	2.7	0.524	2.7	0.562	1.1	4.8
HSR 30HA HSR 30HAM	42	90	120.6	72	52	M10	93	—	9	18	35	7	12	28	31	26	80	9×14×12	37.3	62.5	0.889	4.37	0.889	4.37	0.751	1.3	4.8
HSR 35CA HSR 35CAM	48	100	109.4	82	62	M10	80.4	—	12	21	40.5	8	12	34	33	29	80	9×14×12	37.3	61.1	0.782	3.93	0.782	3.93	0.905	1.6	6.6
HSR 35HA HSR 35HAM	48	100	134.8	82	62	M10	105.8	—	12	21	40.5	8	12	34	33	29	80	9×14×12	50.2	81.5	1.32	6.35	1.32	6.35	1.2	2	6.6
HSR 45CA HSR 45HA	60	120	139 170.8	100	80	M12	98 129.8	25	13	15	50	10	16	45	37.5	38	105	14×20×17	60 80.4	95.6 127	1.42 2.44	7.92 12.6	1.42 2.44	7.92 12.6	1.83 2.43	2.8 3.3	11
HSR 55CA HSR 55HA	70	140	163 201.1	116	95	M14	118 156.1	29	13.5	17	57	11	16	53	43.5	44	120	16×23×20	88.5 119	137 183	2.45 4.22	13.2 21.3	2.45 4.22	13.2 21.3	3.2 4.28	4.5 5.7	15.1
HSR 65CA HSR 65HA	90	170	186 245.5	142	110	M16	147 206.5	37	21.5	23	76	19	16	63	53.5	53	150	18×26×22	141 192	215 286	4.8 8.72	23.5 40.5	4.8 8.72	23.5 40.5	5.82 7.7	8.5 10.7	22.5
HSR 85CA HSR 85HA	110	215	245.6 303	185	140	M20	178.6 236	55	28	30	94	23	16	85	65	65	180	24×35×28	210 282	310 412	8.31 14.2	45.6 72.5	8.31 14.2	45.6 72.5	11 14.7	17 23	35.2

Model number coding **HSR25 HA 2 QZ KKHH C0 M +1300L P M-II**

1 2 3 4 5 6 7 8 9 10 11

- 1 Model number
- 2 Type of LM block
- 3 No. of LM blocks used on the same rail
- 4 With QZ Lubricator
- 5 Dust prevention accessory symbol (see page a-282)
- 6 Radial clearance symbol (see page a-33)
- 7 LM block is made of stainless steel
- 8 LM rail length (in mm)
- 9 Accuracy symbol (see page a-38)
- 10 LM rail is made of stainless steel
- 11 No. of rails used on the same plane

Note This model number indicates that a single-rail unit constitutes one set (i.e., required number of sets when 2 rails are used in parallel is 2 at a minimum). Those models equipped with QZ Lubricator cannot have a grease nipple.

Note Symbol M indicates that stainless steel is used in the LM block, LM rail and balls. Those models marked with this symbol are therefore highly resistant to corrosion and environment.

Static permissible moment* 1 block: static permissible moment value with 1 LM block
2 blocks: static permissible moment value with 2 blocks closely contacting with each other

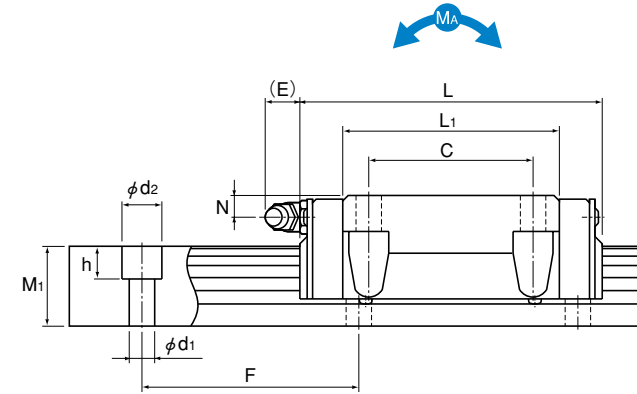
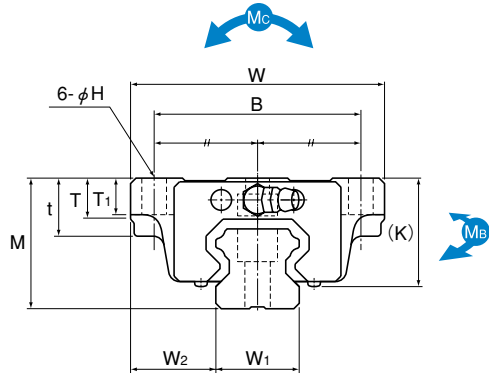

Unit: mm

Model No.	External dimensions			LM block dimensions										Grease nipple	LM rail dimensions				Basic load rating		Static permissible moment kN-m*					Mass	
	Height M	Width W	Length L	B	C	H	L ₁	t	T	T ₁	K	N	E		Width W ₁ ±0.05	W ₂	Height M ₁	Pitch F	d ₁ × d ₂ × h	C	C ₀	M _A 1 block	M _A 2 blocks in close contact	M _B 1 block	M _B 2 blocks in close contact	M _C 1 block	LM block kg
HSR 20CB HSR 20CBM	30	63	74	53	40	6	50.8	10	9.5	10	26	5	12	20	21.5	18	60	6×9.5×8.5	13.8	23.8	0.19	1.04	0.19	1.04	0.201	0.35	2.3
HSR 20HB HSR 20HBM	30	63	90	53	40	6	66.8	10	9.5	10	26	5	12	20	21.5	18	60	6×9.5×8.5	21.3	31.8	0.323	1.66	0.323	1.66	0.27	0.47	2.3
HSR 25CB HSR 25CBM	36	70	83.1	57	45	7	59.5	16	11	10	30.5	6	12	23	23.5	22	60	7×11×9	19.9	34.4	0.307	1.71	0.307	1.71	0.344	0.59	3.3
HSR 25HB HSR 25HBM	36	70	102.2	57	45	7	78.6	16	11	10	30.5	6	12	23	23.5	22	60	7×11×9	27.2	45.9	0.529	2.74	0.529	2.74	0.459	0.75	3.3
HSR 30CB HSR 30CBM	42	90	98	72	52	9	70.4	18	9	10	35	7	12	28	31	26	80	9×14×12	28	46.8	0.524	2.7	0.524	2.7	0.562	1.1	4.8
HSR 30HB HSR 30HBM	42	90	120.6	72	52	9	93	18	9	10	35	7	12	28	31	26	80	9×14×12	37.3	62.5	0.889	4.37	0.889	4.37	0.751	1.3	4.8
HSR 35CB HSR 35CBM	48	100	109.4	82	62	9	80.4	21	12	13	40	8	12	34	33	29	80	9×14×12	37.3	61.1	0.782	3.93	0.782	3.93	0.905	1.6	6.6
HSR 35HB HSR 35HBM	48	100	134.8	82	62	9	105.8	21	12	13	40	8	12	34	33	29	80	9×14×12	50.2	81.5	1.32	6.35	1.32	6.35	1.2	2	6.6
HSR 45CB HSR 45HB	60	120	139 170.8	100	80	11	98 129.8	25	13	15	50	10	16	45	37.5	38	105	14×20×17	60 80.4	95.6 127	1.42 2.44	7.92 12.6	1.42 2.44	7.92 12.6	1.83 2.43	2.8 3.3	11
HSR 55CB HSR 55HB	70	140	163 201.1	116	95	14	118 156.1	29	13.5	17	57	11	16	53	43.5	44	120	16×23×20	88.5 119	137 183	2.45 4.22	13.2 21.3	2.45 4.22	13.2 21.3	3.2 4.28	4.5 5.7	15.1
HSR 65CB HSR 65HB	90	170	186 245.5	142	110	16	147 206.5	37	21.5	23	76	19	16	63	53.5	53	150	18×26×22	141 192	215 286	4.8 8.72	23.5 40.5	4.8 8.72	23.5 40.5	5.82 7.7	8.5 10.7	22.5
HSR 85CB HSR 85HB	110	215 110	245.6 303	185	140	18	178.6 236	55	28	30	94	23	16	85	65	65	180	24×35×28	210 282	310 412	8.31 14.2	45.6 72.5	8.31 14.2	45.6 72.5	11 14.7	17 23	35.2

Model number coding **HSR35 CB 2 QZ ZZHH C0 M +1400L P M- II**



- 1 Model number
- 2 Type of LM block
- 3 No. of LM blocks used on the same rail
- 4 With QZ Lubricator
- 5 Dust prevention accessory symbol (see page a-282)
- 6 Radial clearance symbol (see page a-33)
- 7 LM block is made of stainless steel
- 8 LM rail length (in mm)
- 9 Accuracy symbol (see page a-38)
- 10 LM rail is made of stainless steel
- 11 No. of rails used on the same plane

Note This model number indicates that a single-rail unit constitutes one set (i.e., required number of sets when 2 rails are used in parallel is 2 at a minimum). Those models equipped with QZ Lubricator cannot have a grease nipple.

Note Symbol M indicates that stainless steel is used in the LM block, LM rail and balls. Those models marked with this symbol are therefore highly resistant to corrosion and environment.

Static permissible moment* 1 block: static permissible moment value with 1 LM block
2 blocks: static permissible moment value with 2 blocks closely contacting with each other

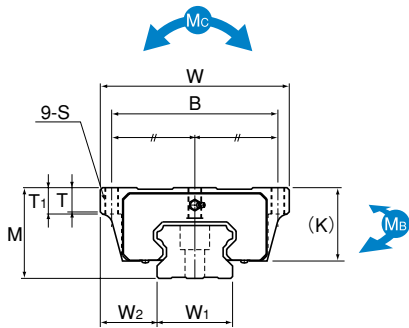

Models HSR100 to 150HA

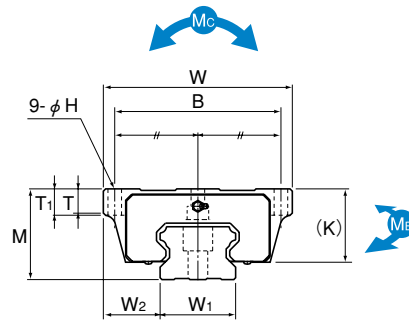

Models HSR100 to 150HB

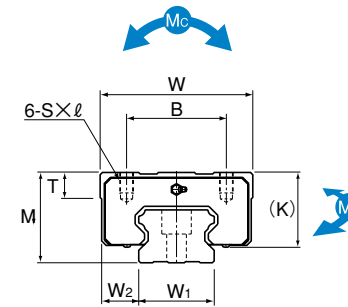

Models HSR100 to 150 HR

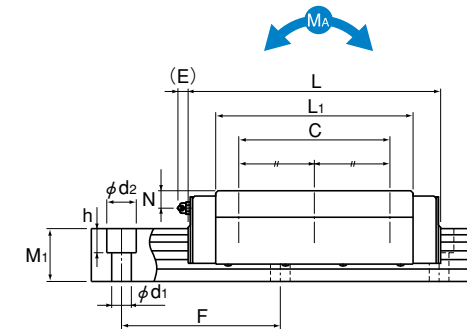

Unit: mm

Model No.	External dimensions			LM block dimensions										LM rail dimensions					Basic load rating		Static permissible moment kN-m*			Mass				
	Height M	Width W	Length L	B	C	H	S × ℓ	L ₁	T	T ₁	K	N	E	Grease nipple	Width W ₁ ±0.05	W ₂	Height M ₁	Pitch F	d ₁ × d ₂ × h	C kN	C ₀ kN	M _A 1 block	M _B 2 blocks in close contact	M _C 2 blocks in close contact	M _C 1 block	LM block kg	LM rail kg/m	
HSR 100HA	120	250	334	220	200	20	M18 **	261	32	35	100	23	16	B-PT1/4	100	75	70	210	26×39×32	351	506	19.4	98.2	19.4	98.2	22.4	32	49
HSR 100HB	200	250	334	220	200	20	—	261	32	35	100	23	16	B-PT1/4	100	75	70	210	26×39×32	351	506	19.4	98.2	19.4	98.2	22.4	32	49
HSR 100HR	200	250	334	130	200	—	M18×27	—	33	—	—	—	—	—	—	—	—	—	—	—	—	—	—	—	—	—	—	—
HSR 120HA	130	290	365	250	210	22	M20 **	287	34	38	110	26.5	16	B-PT1/4	114	88	75	230	33×48×43	429	612	25.9	129	25.9	129	31.1	43	61
HSR 120HB	220	290	365	250	210	22	—	287	34	38	110	26.5	16	B-PT1/4	114	88	75	230	33×48×43	429	612	25.9	129	25.9	129	31.1	43	61
HSR 120HR	220	290	365	146	210	—	M20×30	—	33.7	—	—	—	—	—	—	—	—	—	—	—	—	—	—	—	—	—	—	—
HSR 150HA	145	350	396	300	230	26	M24 **	314	36	40	123	29	16	B-PT1/4	144	103	85	250	39×58×46	518	728	33.6	167	33.6	167	45.2	62	87
HSR 150HB	266	350	396	300	230	26	—	314	36	40	123	29	16	B-PT1/4	144	103	85	250	39×58×46	518	728	33.6	167	33.6	167	45.2	62	87
HSR 150HR	266	350	396	180	230	—	M24×35	—	33	—	—	—	—	—	—	—	—	—	—	—	—	—	—	—	—	—	—	—

Note "*" indicates a through hole.

Note Static permissible moment* 1 block: static permissible moment value with 1 LM block
2 blocks: static permissible moment value with 2 blocks closely contacting with each other

Model number coding

HSR150 HR 2 UU C1 +2350L H- II

1 2 3 4 5 6 7 8

- 1 Model number
- 2 Type of LM block
- 3 No. of LM blocks used on the same rail
- 4 Dust prevention accessory symbol (see page a-282)
- 5 Radial clearance symbol (see page a-33)
- 6 LM rail length (in mm)
- 7 Accuracy symbol (see page a-38)
- 8 No. of rails used on the same plane

Note This model number indicates that a single-rail unit constitutes one set (i.e., required number of sets when 2 rails are used in parallel is 2 at a minimum).

Overall LM Block Length with Options

■ Overall LM Block Length (Dimension L) of Model HSR with a Dust Prevention Accessory Attached

Unit: mm

Model No.	UU	SS	DD	ZZ	KK	LL	RR	SSHH	DDHH	ZZHH	KKHH
HSR 8RM	24	—	—	—	—	—	—	—	—	—	—
HSR 10RM	31	—	—	—	—	—	—	—	—	—	—
HSR 12RM	45	—	—	—	—	—	—	—	—	—	—
HSR 15A/B/R/YR	56.6	56.6	61.8	58.2*	63.4*	56.6	56.6	76	81.2	77.2	82.4
HSR 20A/B/R/CA/CB/YR	74	74	80.6	76.6	83.2	74	74	92	98.6	95.2	101.8
HSR 20LA/LB/LR/HA/HB	90	90	96.6	92.6	99.2	90	90	108	114.6	111.2	117.8
HSR 25A/B/R/CA/CB/YR	83.1	83.1	90.7	86.7	94.3	83.1	83.1	101	108.6	105.3	112.9
HSR 25LA/LB/LR/HA/HB	102.2	102.2	109.8	105.8	113.4	102.2	102.2	120.1	127.7	124.4	132
HSR 30A/B/R/CA/CB/YR	98	98	105.6	101.6	109.2	98	98	119.9	127.5	124.2	131.8
HSR 30LA/LB/LR/HA/HB	120.6	120.6	128.2	124.2	131.8	120.6	120.6	142.5	150.1	146.8	154.4
HSR 35A/B/R/CA/CB/YR	109.4	109.4	117	113	120.6	109.4	109.4	132.4	140	135.6	143.2
HSR 35LA/LB/LR/HA/HB	134.8	134.8	142.4	138.4	146	134.8	134.8	157.8	165.4	161	168.6
HSR 45A/B/R/CA/CB/YR	139	139	146.2	144.2	151.4	139	139	—	—	—	—
HSR 45LA/LB/LR/HA/HB	170.8	170.8	178	176	183.2	170.8	170.8	—	—	—	—
HSR 55A/B/R/CA/CB/YR	163	163	170.2	168.2	175.4	163	163	—	—	—	—
HSR 55LA/LB/LR/HA/HB	201.1	201.1	208.3	206.3	213.5	201.1	201.1	—	—	—	—
HSR 65A/B/R/CA/CB/YR	186	186	193.2	191.2	198.4	186	186	—	—	—	—
HSR 65LA/LB/LR/HA/HB	245.5	245.5	252.7	250.7	257.9	245.5	245.5	—	—	—	—
HSR 85A/B/R/CA/CB/YR	245.6	245.6	252.8	252.4	259.6	—	—	—	—	—	—
HSR 85LA/LB/LR/HA/HB	303	303	310.2	309.8	317	—	—	—	—	—	—
HSR 100HA/HB/HR	334	334	—	—	—	—	—	—	—	—	—
HSR 120HA/HB/HR	365	365	—	—	—	—	—	—	—	—	—
HSR 150HA/HB/HR	396	396	—	—	—	—	—	—	—	—	—

Note: "—" indicates not available.

"*" indicates available, but not support a grease nipple. Contact  for details.

Overall LM Block Length (Dimension L) of Model HSR with QZ Lubricator Attached

Unit: mm

Model No.	QZUU	QZSS	QZDD	QZZZ	QZKK	QZSSH	QZDDH	QZZZH	QZKHH
HSR 15A/B/R/YR	79.6	79.6	87.6	84.2	92.2	98.8	106.8	100	108
HSR 20A/B/R/CA/CB/YR	96.2	96.2	104.4	102	110.2	113.6	121.8	116	124.2
HSR 20LA/LB/LR/HA/HB	112.2	112.2	120.4	118	126.2	129.6	137.8	132	140.2
HSR 25A/B/R/CA/CB/YR	104.1	104.1	112.1	109.8	117.8	121.4	129.4	123.8	131.8
HSR 25LA/LB/LR/HA/HB	123.2	123.2	131.2	128.9	136.9	140.5	148.5	142.9	150.9
HSR 30A/B/R/CA/CB/YR	119	119	127	124.7	132.7	140.3	148.3	142.7	150.7
HSR 30LA/LB/LR/HA/HB	141.6	141.6	149.6	147.3	155.3	162.9	170.9	165.3	173.3
HSR 35A/B/R/CA/CB/YR	132.2	132.2	142	139	148.8	154.6	164.4	157	166.8
HSR 35LA/LB/LR/HA/HB	157.6	157.6	167.4	164.4	174.2	180	189.8	182.4	192.2
HSR 45A/B/R/CA/CB/YR	174.8	174.8	181.6	176.6	186.4	—	—	—	—
HSR 45LA/LB/LR/HA/HB	206.6	206.6	213.4	208.4	218.2	—	—	—	—
HSR 55A/B/R/CA/CB/YR	197.2	197.2	208.4	202	213.2	—	—	—	—
HSR 55LA/LB/LR/HA/HB	235.3	235.3	246.5	240.1	251.3	—	—	—	—
HSR 65A/B/R/CA/CB/YR	221.4	221.4	233.8	226.6	239	—	—	—	—
HSR 65LA/LB/LR/HA/HB	280.9	280.9	293.3	286.1	298.5	—	—	—	—

Basic Specifications of LaCS®

- ① Service temperature range of LaCS: -20°C to +80°C
- ② Resistance of LaCS: indicated in table 7

Table 7 Resistance of LaCS

Unit: N

Model No.	Resistance of LaCS
HSR 15	3.8
HSR 20	5.6
HSR 25	7.5
HSR 30	14.9
HSR 35	22.4

Note 1: Each resistance value in the table only consists of that of LaCS, and does not include sliding resistances of seals and other accessories.

Note 2: For the maximum service speed of LaCS, contact THK.

Grease Nipple

Those LM Guide models without QZ Lubricator are equipped with a grease nipple. Fig. 7 shows the mounting location for the grease nipple. Please note that attaching the grease nipple increases the LM block width.

■ For LM Guide Models with Dust Prevention Accessories SSHH, DDHH, ZZHH or KKHH

LM Guide models with dust prevention accessories SSHH, DDHH, ZZHH or KKHH have the grease nipple in the location indicated in Fig. 7.

Table 8 shows incremental dimensions with the grease nipple.

Table 8

Unit: mm

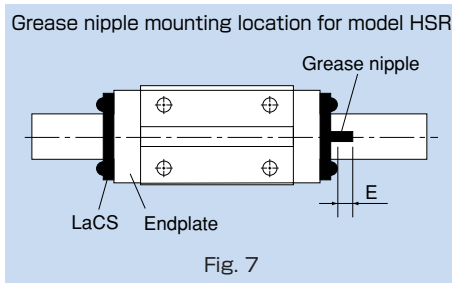

Model No.	Incremental dimension with grease nipple E	Nipple type
HSR 15A/B/R/YR	2.9	PB1021B
HSR 20A/B/R/CA/CB/YR HSR 20LA/LB/LR/HA/HB	9.4	B-M6F
HSR 25A/B/R/CA/CB/YR HSR 25LA/LB/LR/HA/HB	9.0	B-M6F
HSR 30A/B/R/CA/CB/YR HSR 30LA/LB/LR/HA/HB	9.0	B-M6F
HSR 35A/B/R/CA/CB/YR HSR 35LA/LB/LR/HA/HB	8.0	B-M6F

Note: When desiring the mounting location for the grease nipple other than the one indicated in Fig. 7, contact **THK**.

■ For LM Guide Models with Dust Prevention Accessories UU or SS

For the mounting location of the grease nipple (N) and its incremental dimension (E) when dust prevention accessories UU or SS are attached, see the corresponding tables of dimensions on pages a-290 to a-305.

■ For LM Guide Models with Dust Prevention Accessories DD, ZZ or KK

For the mounting location of the grease nipple and its incremental dimension when dust prevention accessories DD, ZZ or KK are attached, contact **THK**.

Model number coding

HSR25 A 2 QZ KKHH C1 +760L P

1

2

3

1 LM Guide model number

2 QZ: with QZ Lubricator, without grease nipple No symbol: without QZ Lubricator (note 2)

3 Dust prevention accessory symbol (see page a-282)

Note 1: QZ Lubricator and LaCS are not sold alone.

Note 2: Those models equipped with QZ Lubricator cannot have a grease nipple. When desiring both QZ Lubricator and the grease nipple to be attached, contact **THK**.

Precautions on Use

■ Laminated Contact Scraper LaCS for LM Guides

Service environment

- Be sure the service temperature range of Laminated Contact Scraper LaCS is between -20°C and $+80^{\circ}\text{C}$, and do not clean LaCS in an organic solvent or white kerosene, or leave it unpacked.

Impregnating oil

- The lubricant impregnated into Laminated Contact Scraper LaCS is used to increase the sliding capability of LaCS itself. For lubrication of the LM Guide, attach QZ Lubricator or the grease nipple.

Function

- The intended role of Laminated Contact Scraper LaCS is to remove foreign matter or liquids. To seal oils, end seals are needed.

Design

- When using Laminated Contact Scraper LaCS, be sure to use the dedicated cap C for LM rail mounting holes or an appropriate form of cover.

■ QZ Lubricator for LM Guides

Handling

- Dropping or hitting this product may damage it. Take much care when handling it.
- Do not clean it with an organic solvent or white kerosene.
- Do not leave it unpacked for a long period of time.
- Do not block the air vent with grease or the like.

Service temperature range

- Be sure the service temperature of this product is between -10°C and $+50^{\circ}\text{C}$. When using it beyond the service temperature range, contact .

Use in a special environment

- When using it in a special environment, contact .

Precaution on selection

- Be sure the stroke is longer than the overall length of the LM block length attached with QZ Lubricator.

Corrosion prevention of LM Guides

- QZ Lubricator is a lubricating device designed to feed a minimum amount of oil to the ball raceway of LM rails, and does not provide corrosion prevention to the whole LM Guide. When using it in an environment subject to a coolant or the like, we strongly recommend applying grease or other anti-corrosion agent to the mounting base surface and the LM rail end surfaces of the LM Guide as an anti-corrosion measure.