

Rexroth Ball Rail Systems Standard Runner Blocks, Steel Version

Runner Block 1623-

Slimline, long

Versions:

- Runner block without ball retainer: for part numbers, see table
- Runner block with ball retainer: part numbers 1623-...-22

Dynamic Characteristics

Speed $v_{\max} = 5 \text{ m/s}$

Acceleration $a_{\max} = 500 \text{ m/s}^2$

Other technical data, see chapter "General Technical Data and Calculations".

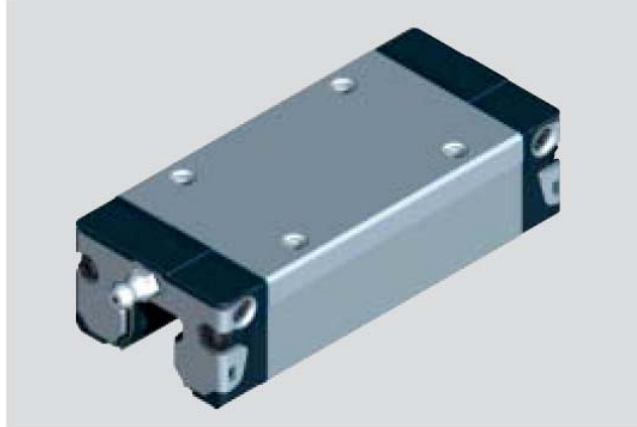

Part numbers

Size	Accuracy class	Part numbers for runner blocks for preload class			
		up to approx. 10 μm clearance	Preload 0.02 C	Preload 0.08 C	Preload 0.13 C
15	N	1623-194-20	1623-114-20		
	P		1623-812-20	1623-822-20	1623-832-20
20	H	1623-893-20	1623-813-20	1623-823-20	
	N	1623-894-20	1623-814-20	1623-824-20	
25	P		1623-212-20	1623-222-20	1623-232-20
	H	1623-293-20	1623-213-20	1623-223-20	
	N	1623-294-20	1623-214-20	1623-224-20	
30	P		1623-712-20	1623-722-20	1623-732-20
	H	1623-793-20	1623-713-20	1623-723-20	
	N	1623-794-20	1623-714-20	1623-724-20	
35	P		1623-312-20	1623-322-20	1623-332-20
	H	1623-393-20	1623-313-20	1623-323-20	
	N	1623-394-20	1623-314-20	1623-324-20	
45*	P		1623-412-20	1623-422-20	1623-432-20
	H	1623-493-20	1623-413-20	1623-423-20	
	N	1623-494-20	1623-414-20	1623-424-20	

* Under preparation

Note on dynamic load capacities and moments (see table)

Determination of dynamic load capacities and moments is based on a travel life of 100 000 m.

However, frequently this is determined on the basis of only 50 000 m.

In this case for comparison: multiply values C , M_t and M_l by 1.26 in accordance with Rexroth table.

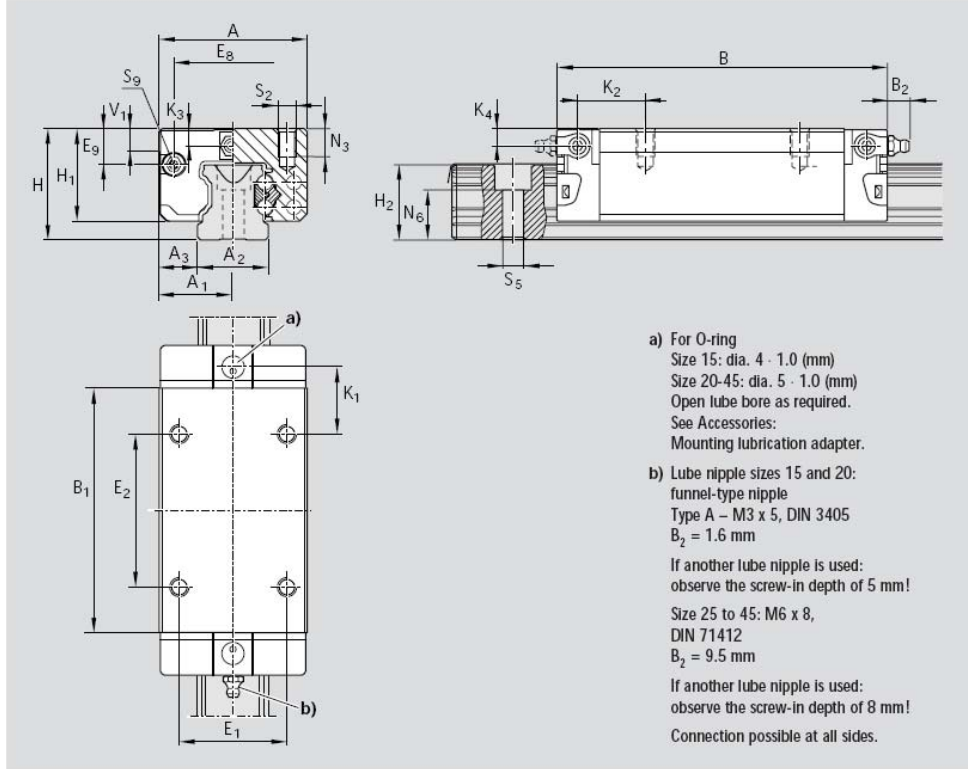

Dimensions (mm)																			
Size	A	A ₁	A ₂	A ₃	B	B ₁	H	H ₁	H ₂ ¹⁾	H ₂ ²⁾	V ₁	E ₁	E ₂	E ₈	E ₉	K ₁	K ₂	K ₃	K ₄
15	34	17	15	9.5	72.6	53.6	24	19.90	16.30	16.20	5.0	26	26	24.55	6.70	17.20	18.80	3.20	3.20
20	44	22	20	12.0	91.0	65.6	30	25.35	20.75	20.55	6.0	32	50	32.50	7.30	14.80	14.80	3.35	3.35
25	48	24	23	12.5	107.9	79.5	36	29.90	24.45	24.25	7.5	35	50	38.30	11.50	20.80	21.95	5.50	5.50
30	60	30	28	16.0	119.7	89.4	42	35.35	28.55	28.35	7.0	40	60	48.40	14.60	21.00	22.70	6.05	6.05
35	70	35	34	18.0	139.0	105.5	48	40.40	32.15	31.85	8.0	50	72	58.00	17.35	23.75	25.25	6.90	6.90
45	86	43	45	20.5	174.1	133.5	60	50.3	40.15	39.85	10.0	60	80	69.8	20.90	35.50	37.50	8.20	8.20

¹⁾ Dimension H₂ with rail seal cover strip

²⁾ Dimension H₂ without rail seal cover strip

Size	N ₃	Dimensions (mm)				Mass (kg)	Load capacities (N) ³⁾		Moments (Nm)			
		N ₆ ^{±0.5}	S ₂	S ₅	S ₉		C dyn.	C ₀ stat.	M _L dyn.	M _{L0} stat.	M _L dyn.	M _{L0} stat.
15	6.0	10.3	M4	4.4	M2.5-3.5 deep	0.20	10 000	20 200	130	190	98	150
20	7.5	13.2	M5	6.0	M3-5 deep	0.45	24 400	35 200	310	450	225	330
25	9.0	15.2	M6	7.0	M3-5 deep	0.65	30 400	45 500	430	650	345	510
30	12.0	17.0	M8	9.0	M3-5 deep	1.10	40 000	57 800	690	1 000	495	715
35	13.0	20.5	M8	9.0	M3-5 deep	1.70	55 600	81 000	1 200	1 740	830	1 215
45	18.0	23.5	M10	14.0	M4-7 deep	3.20	90 400	128 500	2 440	3 470	1 700	2 425

³⁾ Load capacities for version without ball retainer. Load capacities for version without ball retainer, see Product Overview with Load Capacities.