

***Electrak 5 Series  
Electromechanical Linear Actuators***

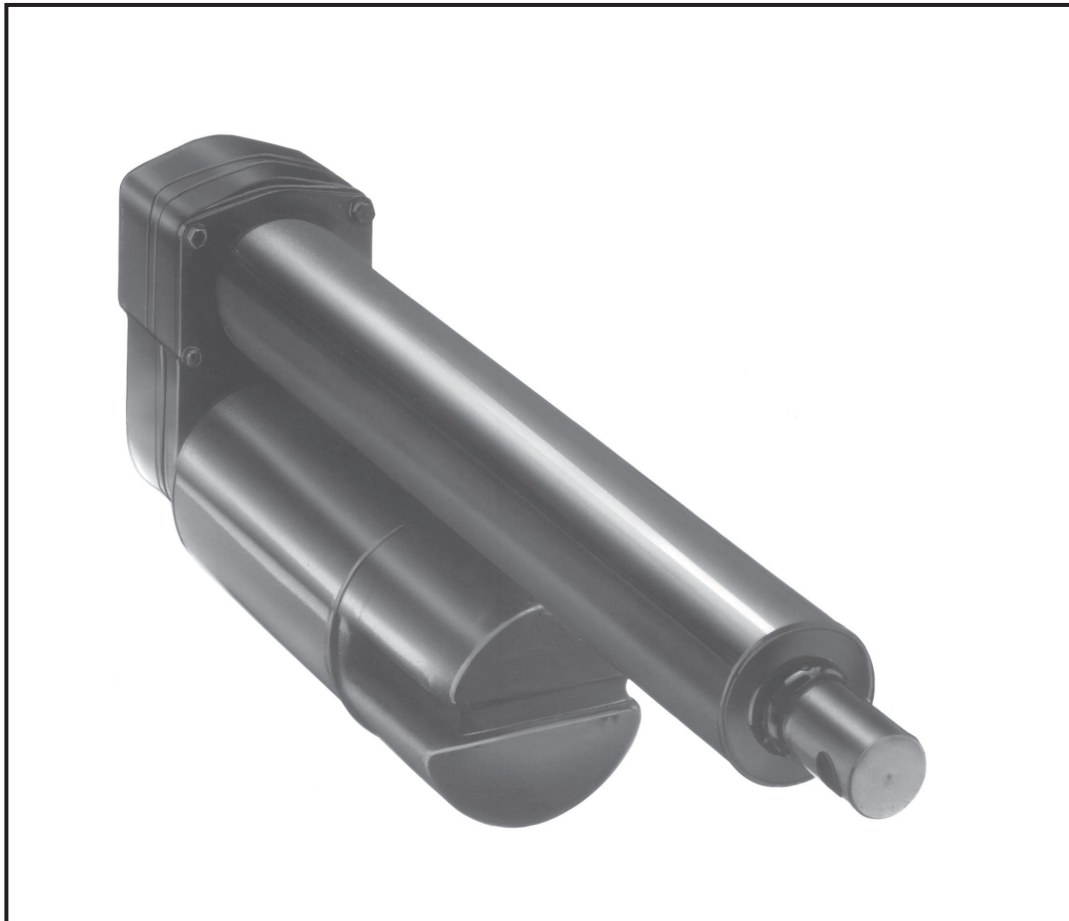

## INTRODUCTION

Thomson has many years of experience designing and manufacturing linear actuators for a wide variety of applications on combines, school buses, industrial sweepers, vans for the handicapped, and other mobile applications. The Thomson linear actuator you have purchased is a well designed, high quality unit which will provide consistent, maintenance-free service throughout its life. With 115 or 230 VAC input power and linear force capability of 500 or 1000 lbs., the Electrak 5 is ideally suited for in-plant applications requiring moving, positioning, adjusting, or opening and closing. To further enhance its in-plant capability, Electrak 5

incorporates a stainless steel extension tube and moisture and dust sealing of the motor.

This manual provides complete information needed to install and troubleshoot A12 or A22 Linear Actuators. This product is easy to apply and requires no maintenance. Please follow the instructions provided in this manual carefully to ensure safe, reliable operation. The Application Notes found on page 5 are of paramount importance, so be sure to read them carefully. All stated or implied manufacturer's warranties are voided if this product is not installed and operated in accordance with these instructions.

## TABLE OF CONTENTS

Description	Page
Other Actuator Products.....	3
Controls .....	4
Application Notes .....	5
Specifications .....	5
Mounting .....	6
Electrical Connection.....	7
Troubleshooting .....	8
Dimensions .....	9

## WARRANTY

Thomson warrants that it will repair or replace (whichever it deems advisable) any product manufactured and sold by it which proves to be defective in material or workmanship within a period of one (1) year from the date of original purchase for consumer, commercial or industrial use.

This warranty extends only to the original purchaser and is not transferable or assignable without Danaher's prior consent.

Warranty service can be obtained in the U.S.A. by returning any defective product, transportation charges prepaid, to the appropriate Thomson factory. Additional warranty information may be obtained by writing the Customer Service Department:

Thomson  
1300 N. State St.  
Marengo, Il. 60152  
Phone: 1-800-554-8466

A purchase receipt or other proof of original purchase will be required before warranty service is rendered. If found defective under the terms of this warranty, repair or replacement will be made, without charge, together with a refund for transportation costs. If found not to be defective, you will be notified and, without your consent, the item will be repaired or replaced and returned to you at your expense.

This warranty covers normal use and does not cover damage or defect which results from alteration, accident, neglect, or improper installation, operation, or maintenance. Some states do not allow limitation on how long an implied warrant lasts, so the above limitation may not apply to you.

Thomson's obligation under this warranty is limited to the repair or replacement of the defective product and in no event shall Danaher be liable for consequential, indirect, or incidental damages of any kind incurred by reason of the manufacturer, sale or use of any defective product. Thomson neither assumes nor authorizes any other person to give any other warranty or to assume any other obligation or liability on its behalf.

WITH RESPECT TO CONSUMER USE OF THE PRODUCT, ANY IMPLIED WARRANTIES WHICH THE CONSUMER MAY HAVE ARE LIMITED IN DURATION TO ONE YEAR FROM THE DATE OF ORIGINAL CONSUMER PURCHASE. WITH RESPECT TO COMMERCIAL AND INDUSTRIAL USES OF THE PRODUCT, THE FOREGOING WARRANTY IS IN LIEU OF AND EXCLUDES ALL OTHER WARRANTIES, WHETHER EXPRESS OR IMPLIED BY OPERATION OF LAW OR OTHERWISE, INCLUDING, BUT NOT LIMITED TO, ANY IMPLIED WARRANTIES OF MERCHANTABILITY OR FITNESS.

Some states do not allow the exclusion or limitation of incidental or consequential damages, so the above limitation or exclusion may not apply to you. This warranty gives you specific legal rights and you may also have other rights which vary from state to state.

## Other Actuator Products

Thomson's family of actuators offers the right load capacity, stroke length, and control package for almost every application. With stroke lengths from 2 to 24 inches, load ratings from 25 to 1000 lbs., AC or DC models, and control systems from simple on-off control to sophisticated closed loop sensing types, Danaher actuator systems

encompass a broad product range. The actuator series described on this page are available at your local Thomson distributor or directly from the address on the back cover of this manual.

Ask for catalog no. P-786 for more information on these products.

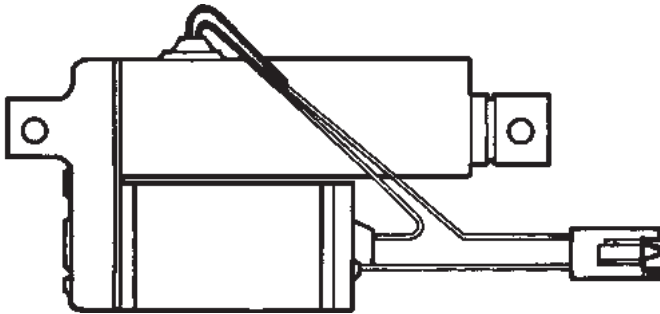

Electrak 1 – Nominal load capacities in a small package.  
 Load Ratings: 25 or 75 lbs. max.  
 Stroke Lengths: 2, 4, or 6 inches  
 Power Input: 12 or 24 VDC  
 Overall Lengths: 7 to 11 inches, depending on stroke.

Electrak 2 – Economy actuator for light load applications.

Load Ratings: 250 lbs. max.  
 Power Input: 12 VDC  
 Stroke Lengths: 4, 6, or 12 inches

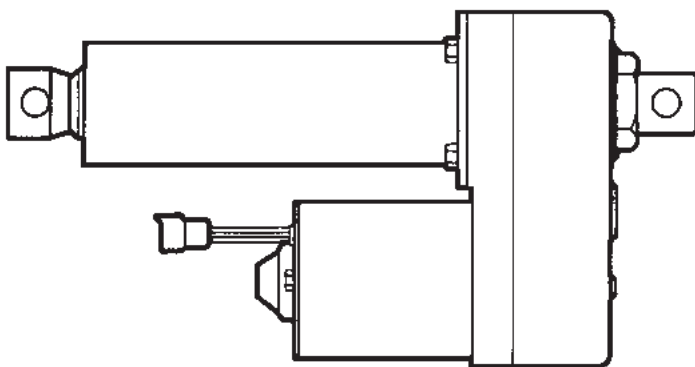
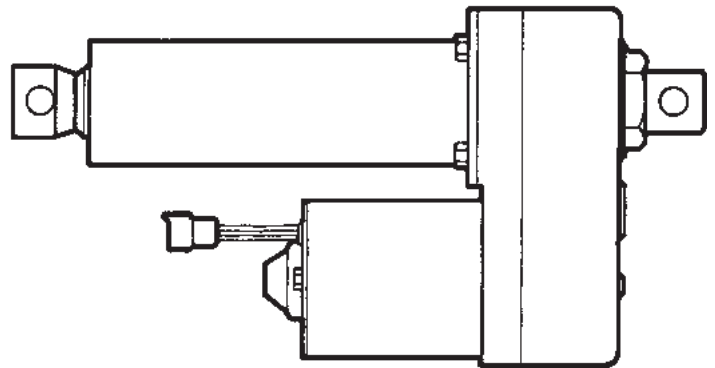

Electrak 10 – The outdoor actuators – designed for mobile equipment.

Load Ratings: 500 or 1000 lbs. max.  
 Power Input: 12 or 24 VDC  
 Stroke Lengths: 4, 6, or 12 inches

Electrak 100 – Potentiometer position feedback control and internal adjustable limit switches make this Thomson's most sophisticated actuator.

Load Ratings: 500 or 1000 lbs.  
 Power Input: 24 VDC  
 Stroke Lengths: 4, 8, 12, 18, or 24 inches  
 Feedback: 10K ohm potentiometer

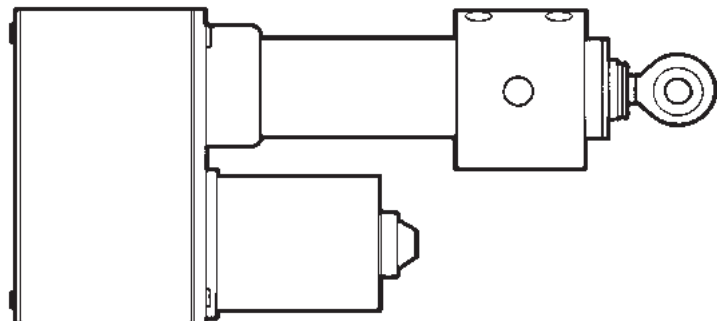

The Thomson family of actuator controls - a choice of separate or combined power supplies and controls to meet your various needs.

**MCS-2015**

A power supply for use with a remote control station, photoscanner or programmable controller to run any 24 VDC actuator. 115/230 VAC input, 24 VDC output, thermal overload protection, fused, power on/off switch.



**MCS-2025**

Combines the power supply of the MCS-2015 and the control of the PC compatible MCS 2020 in a single enclosure for ease of installation and wiring.



**MCS-2020**

A control that can be used with the MCS-2015 or other 12 or 24 VDC power sources. Provides extend, retract, jog, run and auto return functions. Programmable controller compatible, 12 or 24 VDC input-output.



**MCS-2035**

Combines the power supply of the MCS-2015 and the control of the PC compatible MCS-2030 in one enclosure for ease of installation and wiring.



**MCS-2030**

Same as the MCS-2020 but includes an analog meter to display the position feedback from the Electrak 100.



**MCS-2041**

**MCS-2042**

Electrak 5 controls which switch both the actuator motor and anti-coast brake. Rocker switch on control face extends and retracts actuator. Includes motor run capacitor.

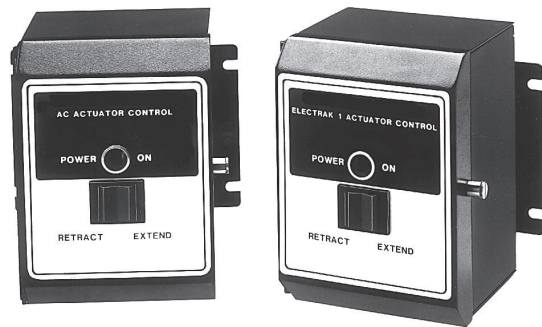

**MCS-2005**

A simple control which converts a 120 VAC input to 24 VDC to operate an Electrak 1 actuator. Rocker switch controls extend/retract of actuator.

**MCS-2041 115 VAC**

**MCS-2042 230 VAC**

### Application Notes — A12, A22 Series

1. Always make sure power is off before attempting to work on or near the actuator and its electrical controls.
2. Electrak 5 actuators are load protected with a slip clutch. The clutch will slip when the load exceeds the actuator's rating, (preventing any movement of the load), or when the actuator reaches the end of its stroke. Clutch is factory set based on load rating.
3. The duty cycle for the Electrak 5 is twenty-five percent "on-time." For instance, an actuator operating for 25 seconds must remain off 75 seconds before operating again. Exceeding this maximum will cause the motor to overheat and trip its internal thermal breaker.
4. The Electrak 5 will not start under load without a capacitor correctly installed.
5. An electrically released solenoid brake limits coasting when power is turned off. This brake must be correctly wired (orange and white wires) for the actuator to extend or retract.
6. Electrak 5 actuators are of TENV construction for use in dirty, damp or oily applications. To assure consistent trouble-free performance, shield the actuator from direct rain. Actuators are not waterproof and should not be used in underwater conditions.
7. Electrak 5 actuators are factory lubricated for life. No disassembly is ever required for routine maintenance purposes.
8. Electrak 5 actuators are **not** explosion or dust ignition proof; do **not** use in those types of environments.
9. Design system to withstand maximum thrust actuator can deliver before the clutch slips (see Overload Protection).

### Specifications — A12, A22 Series

<b>Stroke Length:</b>	4, 8, 12, 18, and 24
<b>Duty Cycle:</b>	Twenty-five percent "on" time at 75°F (lower duty cycle at higher temperatures and amp draws); 20,000 cycles, nominal.
<b>Motor Protection:</b>	Automatically reset thermal overload protection.
<b>Temperature Range:</b>	-15°F to +150°F
<b>End Play:</b>	.045 inch maximum
<b>Overload Protection:</b>	Mechanical load limit clutch set at 900 lb. maximum for 500 lb. actuators Mechanical load limit clutch set at 1600 lb. maximum for 1000 lb. actuators
<b>Mounting:</b>	Actuator ends must be restrained from rotating (to counter 100 in-lb maximum torque developed) and mounted with parallel ½ inch solid pins equally supported on both ends, (see mounting instructions).
<b>Lead Wires:</b>	18 gauge (4 wires)
<b>Static Loads:</b>	3000 lbs.

### Nominal Performance

Model	Volts	Max. Load	Max. Amps	Speed at Max. Load
A12-05B5	115 VAC	500#	2.85	1.80 in./sec.
A22-05B5	230 VAC	500#	1.55	1.80 in./sec.
A12-10B5	115 VAC	1000#	2.85	.90 in./sec.
A22-10B5	230 VAC	1000#	1.55	.90 in./sec.

## Mounting — A12, A22 Series

Thomson linear actuators are quickly and easily mounted by slipping pins through the holes on each end of the unit and into brackets on the machine frame and the load.

Half inch diameter solid pins provide maximum holding strength and a retaining or cotter pin on each end will prevent the solid pin from falling out of its mounting bracket. Roll or spring type mounting pins should be avoided. The mounting pins must be parallel to each other as shown in Figure 1. Pins which are not parallel to each other may cause the actuator to bind.

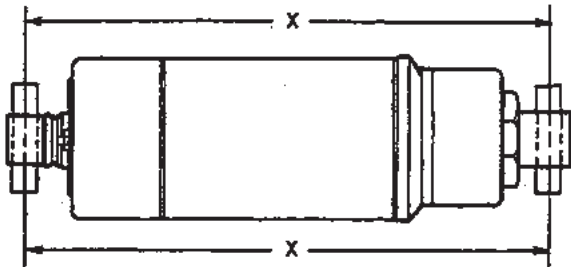

FIGURE 1

The load should act along the stroke axis of the actuator since off center loads may cause binding and lead to premature failure. See Figure 2.

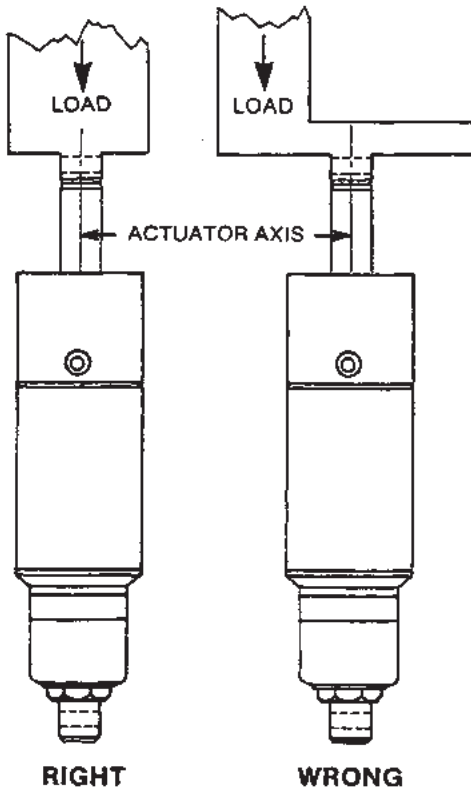

FIGURE 2

The actuator mounting brackets must be able to withstand the torque which is developed when the unit extends or retracts. Restraining torque required is 120 in.-lbs, as designated in Figure 3.

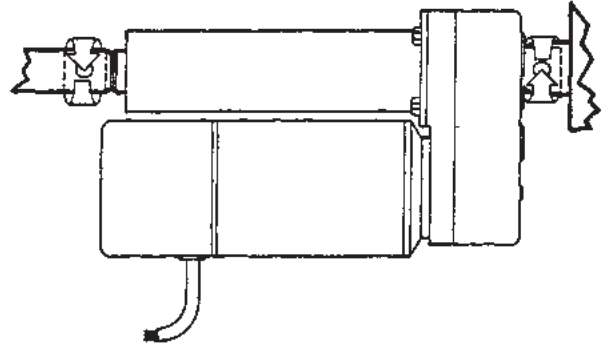

FIGURE 3

Make sure mounting pins are supported on both ends. Cantilever mounts are unacceptable. See Figure 4. Failure to properly support the pins could shorten the life of the actuator.

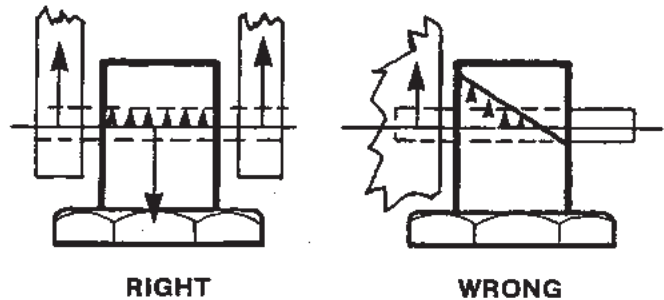
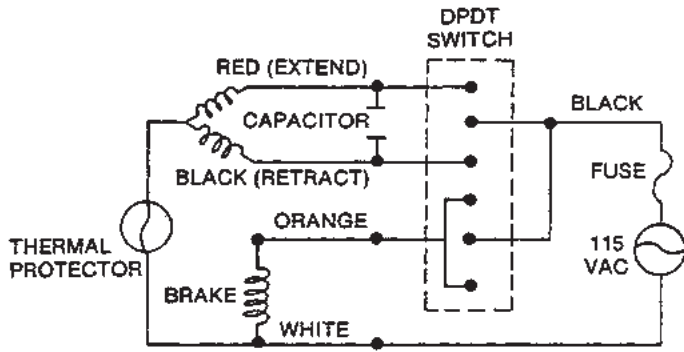

FIGURE 4

Note: A12 and A22 series actuators should **not** be tube mounted.

## Electrical Installation — A12, A22 Series



**NOTE:** Actuator will not extend or retract if either brake (orange and white wires) or capacitor are not correctly wired.

AC actuator motor leads are pre-stripped for installation convenience.

### Capacitors

Thomson AC actuators series A12, A22 use split capacitor motors which require a capacitor for both starting and running. As shown in the connection diagram above, the capacitor is installed across the motor leads. The capacitor used **must** be capable of both starting and running the motor. Thomson offers capacitors as follows:

Voltage	Capacitor	Part Number
115 VAC	35 mfd, 240 VAC	9200-448-002
230 VAC	10 mfd, 370 VAC	9200-448-003

### AC Actuator Switches

AC actuators series A12, A22 require double pole, double throw switches. These can be purchased locally or from Thomson under part number 830-8004-016.

### Switch Specifications

**Type:** Double Pole, Double Throw, Center "off"  
**Capacity:** 15 amp @ 125 VAC  
**Contacts:** 2 momentary contacts  
**Mounting:** 15/32" bushing  
**Terminals:** Screw type

### Wiring

Thomson recommends using 16 gauge wire for applications with distances up to 20 feet from power source to actuator for AC units. For distances ranging from 20 to 60 feet, 14 gauge wire is recommended.

### Wiring For Customer Supplied External Limit Switches AC Actuator

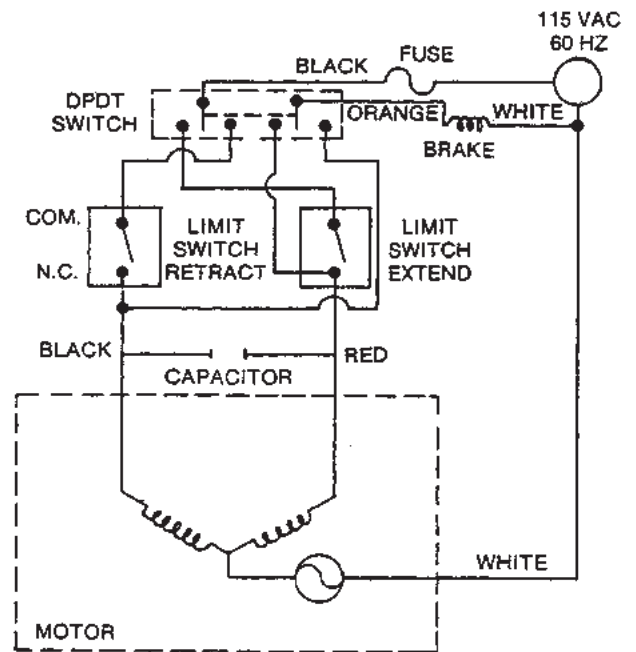

## TROUBLESHOOTING — A12, A22 Series

General: The chart below will be helpful for isolating malfunctions in the control system, countering difficulties with system start-up, and in troubleshooting for worn or broken mechanical or electrical components in units which have been operating for some time. For correct diagnosis it is important to do all tests before disassembling the actuator.

<b>Symptom: Actuator will not extend/retract</b>
--

Checkpoint	Probable Cause	Possible Solution
No voltage or amp draw	Actuator not receiving power	-Check power supply
Proper voltage, no amp draw	Thermal overload cut-out (when overheated)	-Let cool, check duty cycle
	Dead motor	-Replace motor
Motor hums, no movement	Incorrectly wired capacitor	-Check wiring instructions
	Incorrectly wired brake (or brake brown wires not connected)	-Check wiring instructions
Proper voltage, amp draw present, but clutch slips	Actuator overloaded	-Check rated load
	Clutch worn (Excessive ratcheting)	-Replace clutch

<b>Symptom: Actuator stops in mid-stroke</b>
--

Checkpoint	Probable Cause	Possible Solution
Clutch slips, amperage present	Actuator overloaded	-Check rated load
		-Check voltage - may be too low
Clutch doesn't slip, no amperage	Blown fuse (customer provided)	-Replace fuse
	Thermal cut-out	-Let cool, check duty cycle
Clutch doesn't slip, amperage present	Motor stalled	-Check voltage too low

<b>If the above checks do not reveal the source of the difficulty, remove actuator from the mechanism to run by itself. Watch and listen for any changes in behavior.</b>
---



## Dimensions — A12, A22

Stroke Length "A"	"B" (Retracted)
4"	14.95"
8"	18.95"
12"	22.95"
18"	28.95"
24"	34.95"

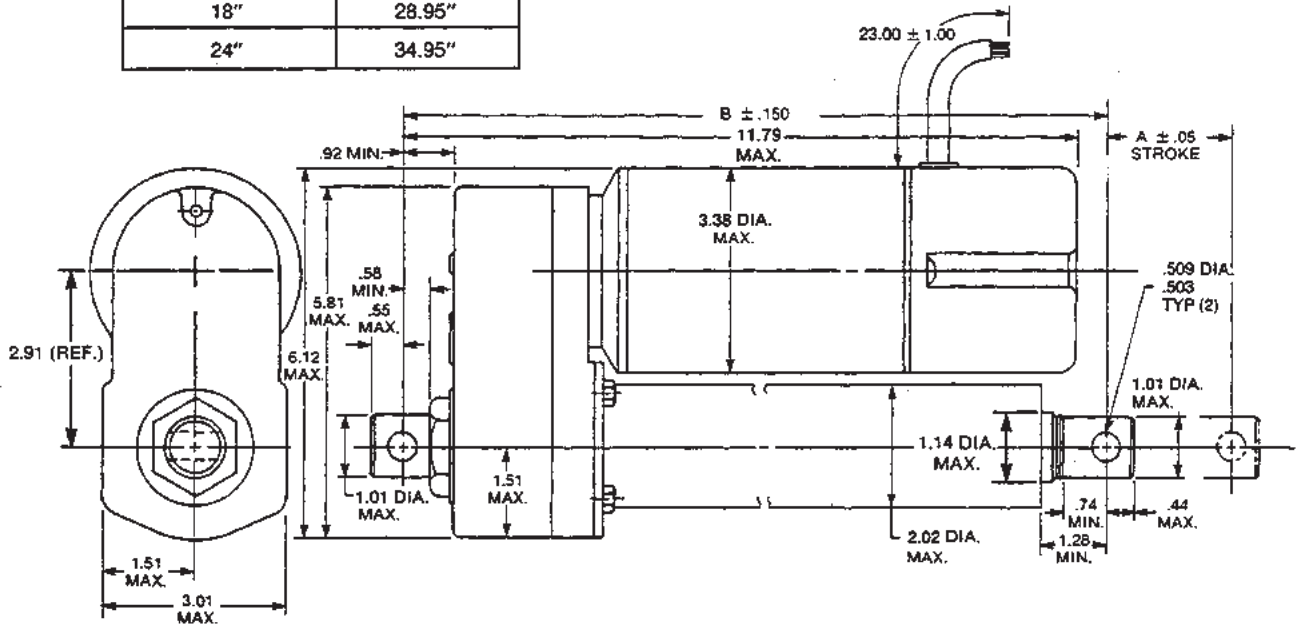

### Ordering Information

Specify model number for appropriate stroke length, voltage, and load capacity. Capacitor and control part numbers are listed below. A control or capacitor is required to operate any Electrak 5 Actuator.

Stroke Length	500 lb. Capacity		1000 lb. Capacity	
	115VAC	230VAC	115VAC	230VAC
4"	A12-05B5-04D	A22-05B5-04D	A12-10B5-04D	A22-10B5-04D
8"	A12-05B5-08D	A22-05B5-08D	A12-10B5-08D	A22-10B5-08D
12"	A12-05B5-12D	A22-05B5-12D	A12-10B5-12D	A22-10B5-12D
18"	A12-05B5-18D	A22-05B5-18D	A12-10B5-18D	A22-10B5-18D
24"	A12-05B5-24D	A22-05B5-24D	A12-10B5-24D	A22-10B5-24D
Controls	MCS-2041	MCS-2042	MCS-2041	MCS-2042
*Capacitor	9200-448-002	9200-448-003	9200-448-002	9200-448-003

\*Must be capable of both starting and running actuator motor. Included in MCS-2041 or MCS-2042 controls.

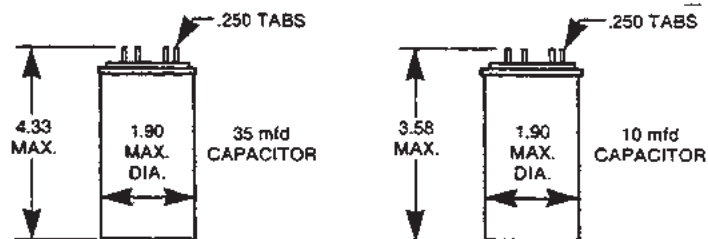

Thomson  
1300 N. State St.  
Marengo, Il. 60152  
Phone: 1-800-554-8466  
Fax: 1-800-445-0329  
[www.thomsonlinear.com](http://www.thomsonlinear.com)

Or write:  
Thomson  
1300 N. State St.  
Marengo, Il. 60152