

**12 and 24 VDC
25 and 75 lb. load capacities**

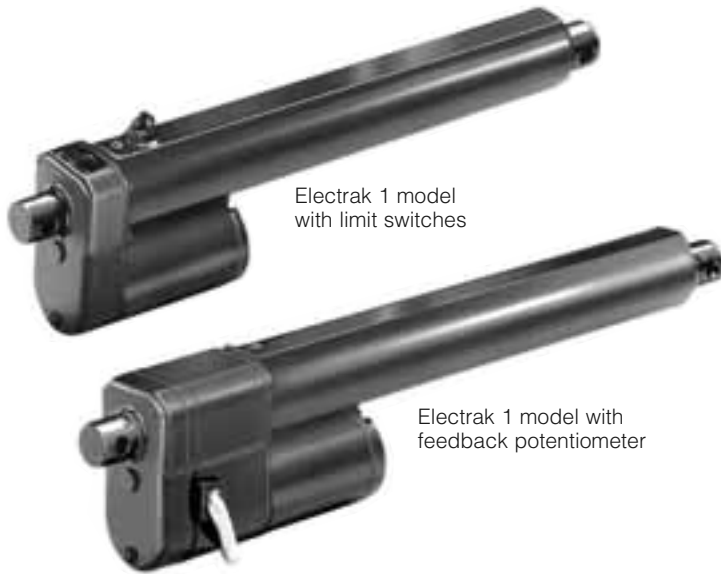

Features

- Acme screw drive delivers as much as 75 pounds of force at a minimum extension speed of .6 in./sec.
- Aluminum/zinc alloy housing resists corrosion and provides protection from dirt, dust and humidity. Operates in temperatures from -15° to 150°F
- Clevis style mounting
- 2, 4, or 6 inch stroke lengths standard
- Completely self-contained in a compact housing – 6 inches of travel from a 10 inch package
- Internal limit switches automatically shut-off unit at the end of stroke or feedback potentiometer provides position signal
- Thermal overload protection in motor

Compact, light duty DC actuators

Completely self-contained and sealed for indoor and outdoor use, Electrak 1 actuators fit into small areas without sacrificing power or reliability. The load/ length configurations available cover a diverse range of intermittent duty applications.

Functionally, Electrak 1 actuators are easily interchanged with comparable size hydraulic or pneumatic cylinders used on intermittent duty applications. The actuator provides consistent, repeatable performance, even for applications with rigorous operating conditions including extreme temperatures, high humidity, and power input variations. Added advantages include no need for adjustment or maintenance due to wear. Electrak 1 actuators are designed for intermittent duty applications requiring lifting, positioning, sorting, opening, clamping and adjusting.

Electrak 1 actuators are available in 2 load ranges, each range offering stroke lengths of 2, 4, or 6 inches. All models feature 12 or 24 VDC input with a plug-in connector and clevis style mounting for easy installation.

Typical applications

- Light load and duty applications
- Short distance operations
- Low cost installations
- Space limitations

Controls

The MCS-2005 is specifically designed for use with the Electrak 1 (24 VDC) actuator and the MCS-2007 for the Electrak 1 actuator with feedback. This actuator can also be operated with the MCS-2015 or MCS-2025 control. See page D-47.

Dimensions

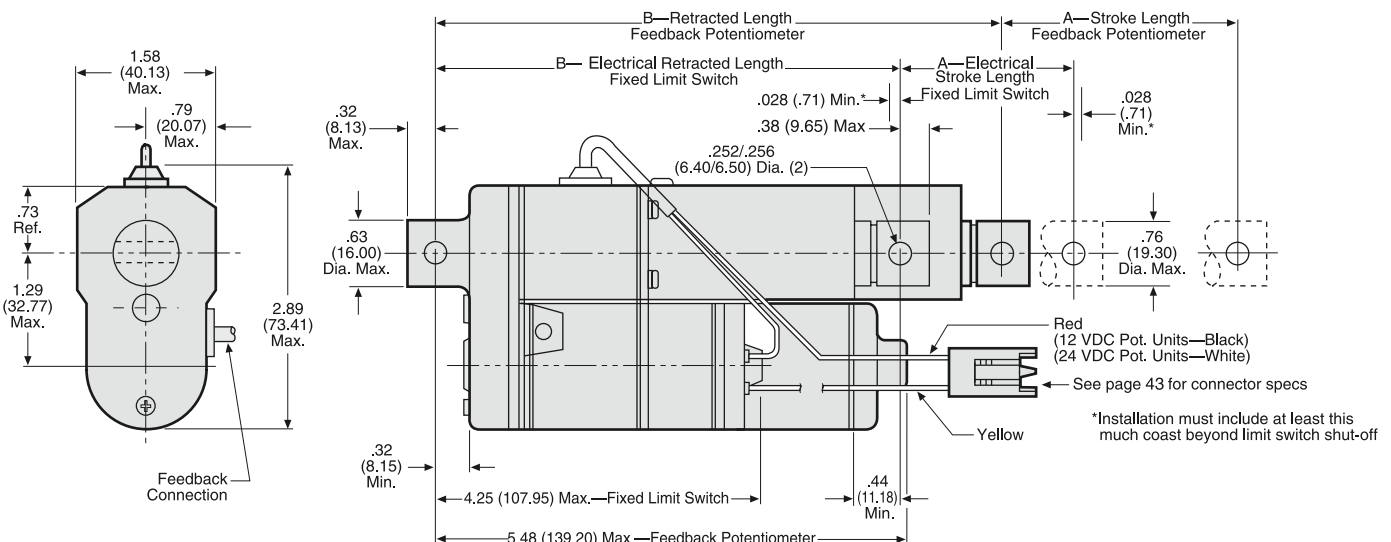

Specifications

Input	12 VDC and 24 VDC
Load capacities	25 or 75 lbs. max.
Stroke lengths	2, 4 or 6 inches
Current draw	3.0 amps maximum at 24 VDC at rated load 5.0 amps maximum at 12 VDC at rated load
Duty cycle	Intermittent, 25% "on time" at rated load per cycle (77° F)
Motor protection	Automatic reset thermal overload
Limit switches	Internal limit switches shutoff on either end of stroke
Thermal Protection	Automatic resetting thermal breaker enclosed in motor housing
Temperature range	-15° F to 150° F
Drive	Acme screw
Connector	Supplied
Mounting	Clevis mounting only
Restraining Torque	Actuator is internally restrained. Extension tube is keyed to cover tube
Static Load	300 lbs. for all strokes

Model Numbers – use when ordering

Stroke Length	Voltage	With fixed limit switches				With potentiometer				Weight lbs.
		Load Capacity		A	B	Load Capacity		A	B	
		25 lbs.	75 lbs.	±.020 (.51)	±.065 (1.65)	25 lbs.	75 lbs.	±.065 (1.65)	±.120 (3.05)	
2	12 VDC	S12-09A4-02	S12-17A8-02	1.82	6.30	SP12-09A4-02	SP12-17A8-02	2.31	7.79	1.25
	24 VDC	S24-09A4-02	S24-17A8-02	(46.23)	(159.89)	SP24-09A4-02	SP24-17A8-02	(58.67)	(197.87)	1.25
4	12 VDC	S12-09A4-04	S12-17A8-04	3.82	8.30	SP12-09A4-04	SP12-17A8-04	4.53	10.01	1.35
	24 VDC	S24-09A4-04	S24-17A8-04	(97.03)	(210.69)	SP24-09A4-04	SP24-17A8-04	(115.06)	(254.25)	1.35
6	12 VDC	S12-09A4-06	S12-17A8-06	5.82	10.30	SP12-09A4-06	SP12-17A8-06	6.75	12.22	1.45
	24 VDC	S24-09A4-06	S24-17A8-06	(147.83)	(261.49)	SP24-09A4-06	SP24-17A8-06	(171.45)	(310.39)	1.45

Note: Feedback rate is based on a full range of 4800 ohms, ie: 2" stroke = 2400 ohms per inch, 4" stroke = 1200 ohms per inch, 6" stroke = 800 ohms per inch.

Performance Curves

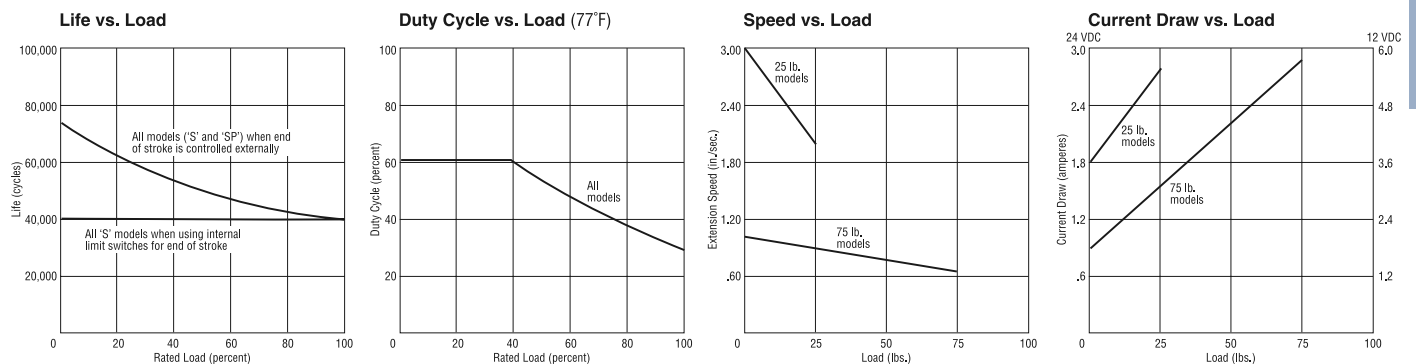

How To Order

