

Rapid Fit Motor Mounts

Specification

The fastest and most economical method of securing motors to machine beds. The five sizes are manufactured from galvanised steel and they can accommodate motor frame sizes 63 to 180. They have four slotted holes for fastening the base to the foundation.

Alignment

The pressed top plate is designed to slide over the base plate preventing vibration and noise whilst ensuring continuous belt alignment. Belts are tensioned by adjusting a single screw.

Motor Mounting

The motor is bolted to the two piece top plate which accommodates a wide range of motors. Centre distance adjustments can be made without the need to loosen the motor bolts.

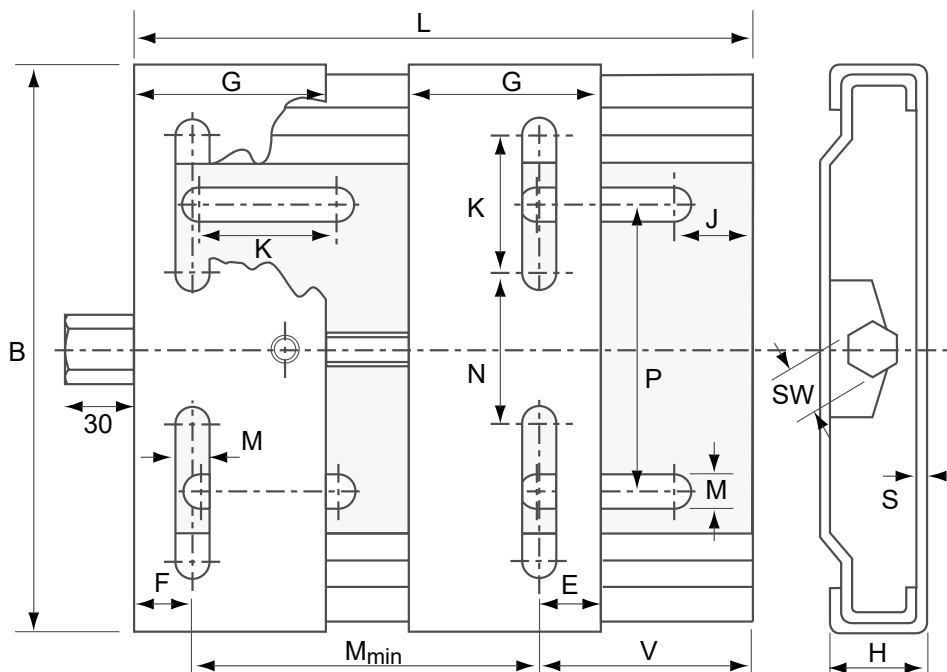

Dimensions for Sizes 210 to 490 Rapid Fit Motor Mount

Type	Frame Size	L	B	H	M _{min}	G	E	J	K	M	Z	P	SW	S
210	63 - 80	210	195	31	100	70	20	25	50.0	10.5	43	90	19	3
270	63 - 100	270	195	31	100	70	20	25	50.0	10.5	43	90	19	3
340	90 - 132	340	290	39	136	95	27	29	62.5	12.5	90	165	22	4
430	90 - 160	430	290	37	136	95	27	29	63.0	12.5	90	165	22	4
490	160 - 180	490	409	37	110	95	40	30	66.0	15.0	193	142/284	22	4

Standard Motor Mounts

Specification

Produced in three sizes for motors from frame size 63 to 225 and manufactured from pressed steel fabrications with four slotted holes for fastening the base to the foundation.

Alignment

The pressed top plate is designed to slide exactly over the mounting rails preventing vibration and noise whilst ensuring continuous belt alignment. Belts are tensioned by adjusting a single screw which is possible whilst the motor is running.

Surface Finish

Stove enamelled finish with zinc plated adjustment screws to prevent corrosion.

Motor Mounting

The top plate requires drilling to accommodate the required motor mounting bolts. Centre distance adjustments can be made without the need to loosen the motor bolts.

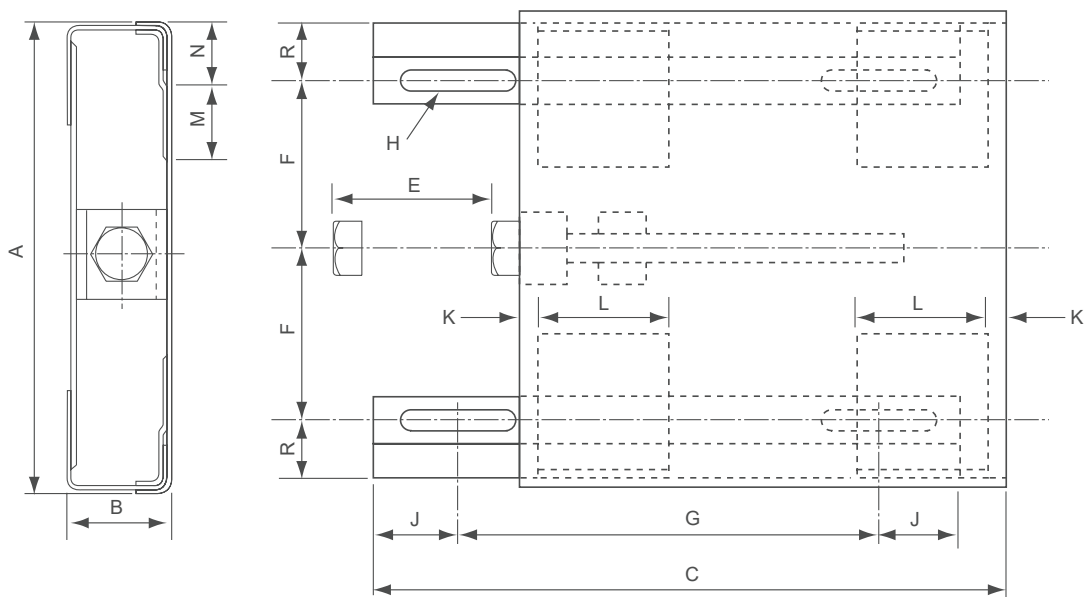

Dimensions for Sizes 0 to B Motor Mounts

Base Ref	Motor Frame Ref	Motor Bolt Holes	A	B	C	D	Movement E	F	G	H	J	K	I	M	N	R	SW	Approx. Weight kg
0	63 71	7	146	29	225	170	80	55.0	148	9.5 x 25	27	60	50	32	18	15.0	17	1.4
A	80 90S 90L	10	240	55	325	258	100	89.0	215	13 x 51	45	10	70	51	32	28.5	24	5.3
	100S 100L 112S 112M 132S	12																
B	132M	12	428	60	578	450	180	172.5	370	17 x 50	51	28	100	98	42	36.0	24	19.0
	160M 160L 180M 180L	15																
	200M 200L 225S 225M	19																