



Split spherical roller bearings

Costs savings through rapid bearing replacement at difficult to access bearing locations

Application examples

Application examples in the pulp and paper industry:

- Fans and ventilators
- Mixing and stirring plant
- Dryer rolls
- Drive and transmission shafts
- Conveying equipment
- Comminution machinery

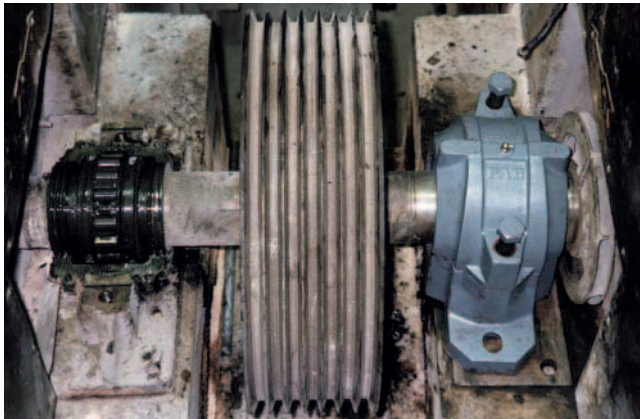

Drive bearing arrangements in conveying and transport equipment

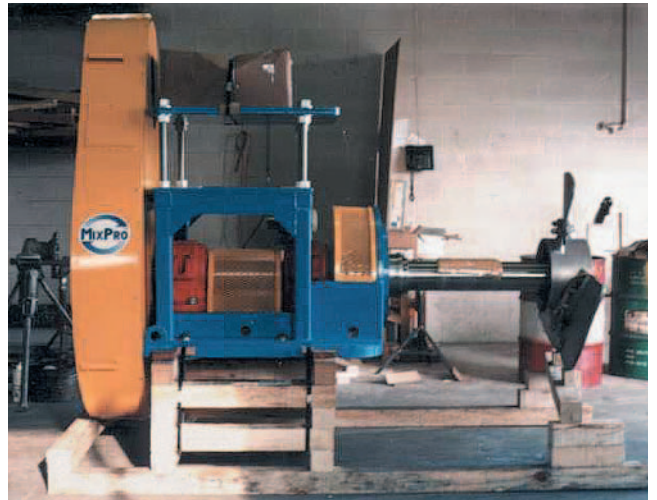

Shaft bearing arrangements in mixing and stirring plant



Bearing arrangements in fans and ventilators



Fitting of a large split spherical roller bearing

Replacement for bearings with adapter sleeve · Fitting in split plummer block housings

Replacement for bearings with adapter sleeve

Split spherical roller bearings can generally be fitted instead of unsplit spherical roller bearings with adapter sleeves. The precondition for replacement is that the outside diameter, outer ring width and diameter of the shaft seat are identical, see Product range, page 5.

Fitting in split plummer block housings

Split spherical roller bearings can be fitted in our split plummer block housings without additional machining of the housings. This also applies to housings from other manufacturers if the internal dimensions are identical.

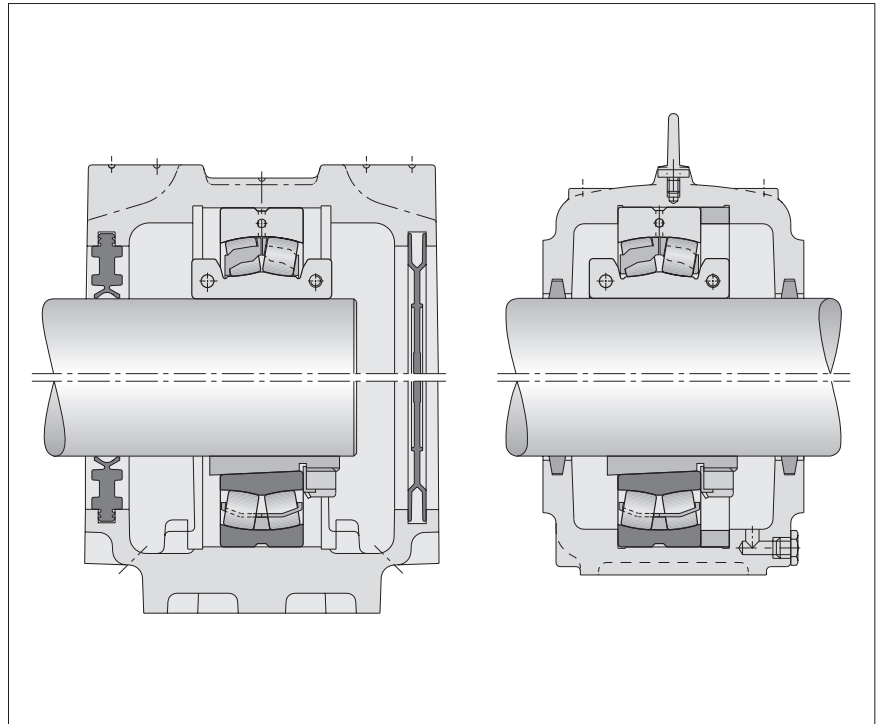

1: Easy bearing replacement since the mounting space of split spherical roller bearings (top) is identical to that of unsplit spherical roller bearings with adapter sleeves (bottom).

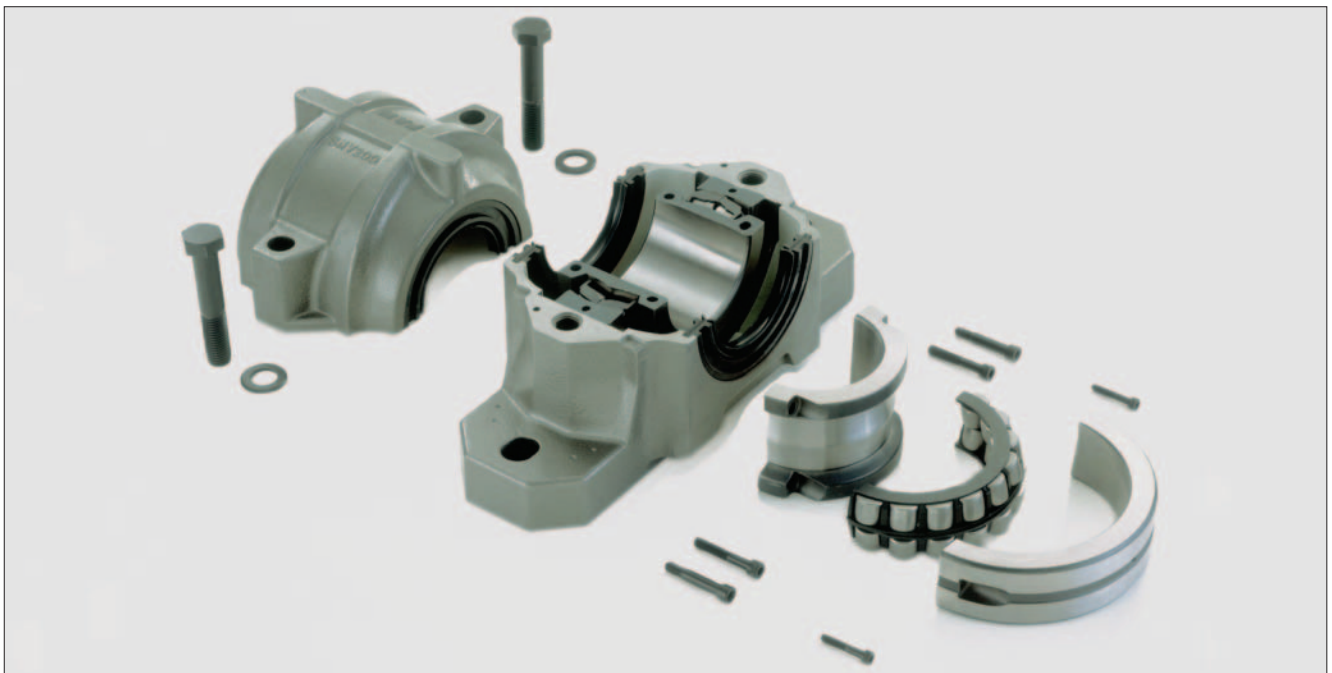

2: Simple inspection, rapid and simple fitting – the split spherical roller bearing to be fitted in an SNV housing

Product range · Bearing design

Product range

Our comprehensive range contains split spherical roller bearings for metric shaft diameters from 55 mm to 630 mm and inch shaft diameters from 2 3/16 inch to 16 inch.

In most cases, the outside diameter, outer ring width and diameter of the shaft seat are identical to those of standard spherical roller bearings of series 222, 230, 231, 239, 240 and 241 with appropriate adapter sleeves.

The bearing tables show which standard bearing with a sleeve can be replaced by the relevant split bearing.

Bearing design

Split spherical roller bearings have a cylindrical bore. The inner ring, outer ring and cage with the roller set are split in half. The split bearing rings are held together by screws.

The internal design of most split spherical roller bearings was carried over from our proven spherical roller bearing E1, Figure 3. The only difference is that some larger bearings have a rigid central rib on the inner ring.

The bearings have a split solid cage made from glass fibre reinforced polyamide or brass (for high temperature suitability, see Catalogue HR 1, Rolling Bearings).

Split spherical roller bearings have the normal tolerances of unsplit radial bearings and the normal internal clearance of unsplit spherical roller bearings with a cylindrical bore (DIN 620). In most split spherical roller bearings, the locking rings are integrated in the inner rings, Figure 4.



4: Split spherical roller bearing with split solid cage made from glass fibre reinforced polyamide or brass, with integral locking rings

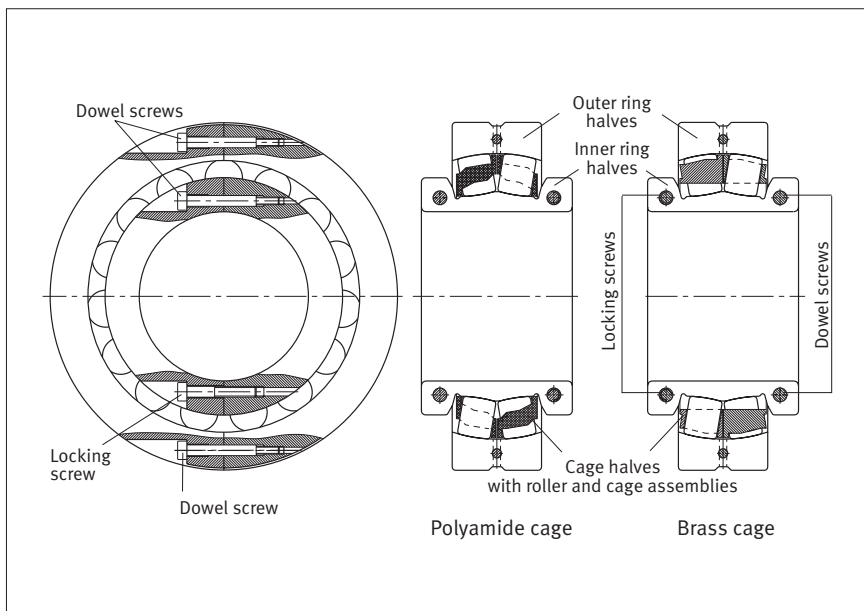

3: The internal design of the bearings with integral locking rings matches that of the proven E1 design.

If there are large differences in temperature between the shaft and inner ring halves, which can occur for example in dryer rolls for paper machinery, bearings with separate locking rings are more suitable, Figure 5.



5: Split spherical roller bearing for special applications with separate, split locking rings

Load carrying capacity · Speed suitability · Fits · Lubrication

Load carrying capacity

The load carrying capacity of split spherical roller bearings is lower than that of unsplit spherical roller bearings, since the pitch circle for the rolling element set is smaller due to the screw connection in the outer ring. Nevertheless, they can achieve a high load carrying capacity since they have the maximum number of rollers with the largest possible dimensions (E1 design). The overrolling of the joints is taken into consideration in calculation of the equivalent dynamic load by applying the shock factor 1,1. Dimensioning is carried out according to the normal calculation method from Catalogue HR 1, Rolling Bearings.

Speed suitability

The limiting speeds are stated in the bearing tables. The values take account of the cage strength and the vibrations generated through overrolling of the joints. If the limiting speeds are exceeded, consultation with Application Engineering is required.

Minimum load

For bearings running at high speeds in particular, a minimum load is required in order to ensure problem-free operation. For these bearings, this is:

$$P = 0,02 \cdot C_r$$

P [kN] Minimum radial load

C_r [kN] Basic radial load rating
from dimension tables

Fits

In order that the inner rings have the necessary firm fit once the screws have been tightened, the shaft must be machined to between h6 and h9. These shaft tolerances are the same as those normally used with unsplit bearings located by means of adapter sleeves. The housing bore is normally machined to H7 or H8.

Lubrication

Split spherical roller bearings are normally lubricated using lithium soap grease of consistency class 2 with EP additives. The lubrication intervals correspond to those of unsplit bearings. Split spherical roller bearings can also be relubricated via a groove and holes in the outer ring.

Automatic lubricators

It is particularly advantageous to use split spherical roller bearings in conjunction with a Motion Guard automatic lubricator. Through controlled relubrication, this continuously supplies a sufficient quantity of fresh grease to the contact points of the rolling bearing. This results in a significant increase in bearing life. These reliable, economical devices give extended lubrication and maintenance intervals and also prevent undersupply or oversupply of grease.

Plant downtime and maintenance costs are reduced as a result. The sparing and environmentally friendly use of lubricants contribute to higher cost-efficiency. Comprehensive information on the Motion Guard lubricators “Champion”, “Compact” and “Concept6” is given in publication WL 81 122.



FAG Spherical roller bearings

Split, in metric sizes

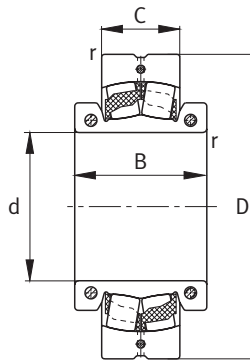
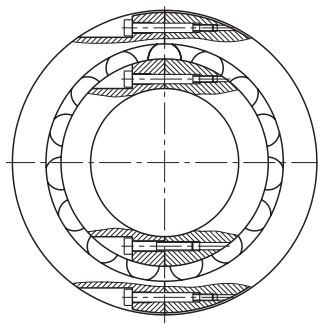

Solid polyamide cage
TVPA

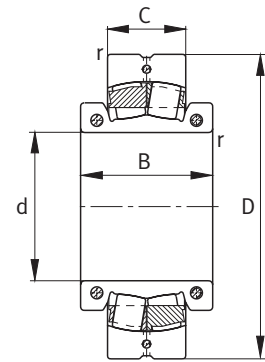

Solid brass cage
MA

Dimension table · Dimensions in mm

Designation	Mass m ≈kg	Dimensions					Basic load ratings		Calculation factors				Fatigue limit load C _{ur} kN
		d	D	C	B	r	dyn. C _r min. kN	stat. C _{0r} kN	e	Y ₁	Y ₂	Y ₀	
222SM55-TVPA	1,47	55	110	28	52	1,5	110	129	0,23	2,92	4,35	2,86	13,2
222SM60-TVPA	1,8	60	120	31	55	1,5	137	156	0,24	2,84	4,23	2,78	15,4
222SM65-TVPA	2,33	65	130	31	60	1,5	173	208	0,24	2,81	4,19	2,75	19,4
222SM70-TVPA	2,95	70	140	33	62	2	180	228	0,23	2,95	4,4	2,89	21,1
222SM75-TVPA	3,55	75	150	36	68	2	183	236	0,22	3,1	4,62	3,03	22,5
222SM80-TVPA	4,28	80	160	40	70	2	212	270	0,22	3,14	4,67	3,07	25,5
222SM85-TVPA	5,11	85	170	43	74	2	260	325	0,22	3,04	4,53	2,97	29
222SM90-TVPA	6,02	90	180	46	76	2,1	285	360	0,23	2,9	4,31	2,83	32,5
231SM100-MA	6,8	100	180	56	90	2	310	430	0,28	2,37	3,53	2,32	40
222SM100-TVPA	8,88	100	200	53	92	2,1	360	465	0,24	2,84	4,23	2,78	39,5
230SM110-MA	5,26	110	180	46	86	2	270	390	0,23	2,9	4,31	2,83	29,5
231SM110-MA	9,51	110	200	62	102	2	390	570	0,28	2,41	3,59	2,35	39
222SM110-TVPA	10,6	110	215	58	98	2,1	455	585	0,25	2,71	4,04	2,65	47
230SM115-MA	9,5	115	200	52	90	2	305	455	0,22	3,04	4,53	2,97	35
231SM115-MA	11,2	115	210	64	104	2	490	710	0,28	2,39	3,56	2,34	49,5
222SM115-TVPA	14,3	115	230	64	104	3	540	720	0,25	2,71	4,04	2,65	53
230SM125-MA	10	125	210	53	94	2	390	600	0,23	2,95	4,4	2,89	44
231SM125-MA	13,5	125	225	68	110	2,1	510	750	0,28	2,45	3,64	2,39	51
222SM125-TVPA	17,9	125	250	68	110	3	630	880	0,26	2,62	3,9	2,56	60
230SM135-MA	13	135	225	56	100	2,1	405	620	0,22	3,07	4,57	3	46
231SM135-MA	19,5	135	250	80	123	2,1	570	850	0,27	2,49	3,71	2,43	57
222SM135-TVPA	24,1	135	270	73	122	3	735	1020	0,25	2,67	3,97	2,61	73
230SM140-MA	15,5	140	240	60	106	2,1	450	680	0,22	3,1	4,62	3,03	51
231SM140-MA	25,8	140	270	86	135	2,1	710	1040	0,29	2,32	3,45	2,26	87
222SM140-TVPA	28,5	140	290	80	124	3	850	1200	0,25	2,69	4	2,63	83

Other designs are also available; please contact us.

Equivalent dynamic load

$$P = 1,1 (F_r + Y_1 \cdot F_a) \quad [\text{kN}] \quad F_a/F_r \leq e$$

$$P = 1,1 (0,67 \cdot F_r + Y_2 \cdot F_a) \quad [\text{kN}] \quad F_a/F_r > e$$

Equivalent static load

$$P_0 = F_{0r} + Y_0 \cdot F_{0a} \quad [\text{kN}]$$

In order to prevent creep of the inner rings in a circumferential direction on the shaft, P/C_r must be $\leq 0,2$. Higher values are permissible if the actual speed is significantly lower than the limiting speed. In such cases, please contact us.

Examples of bearing replacement in plummer block housings

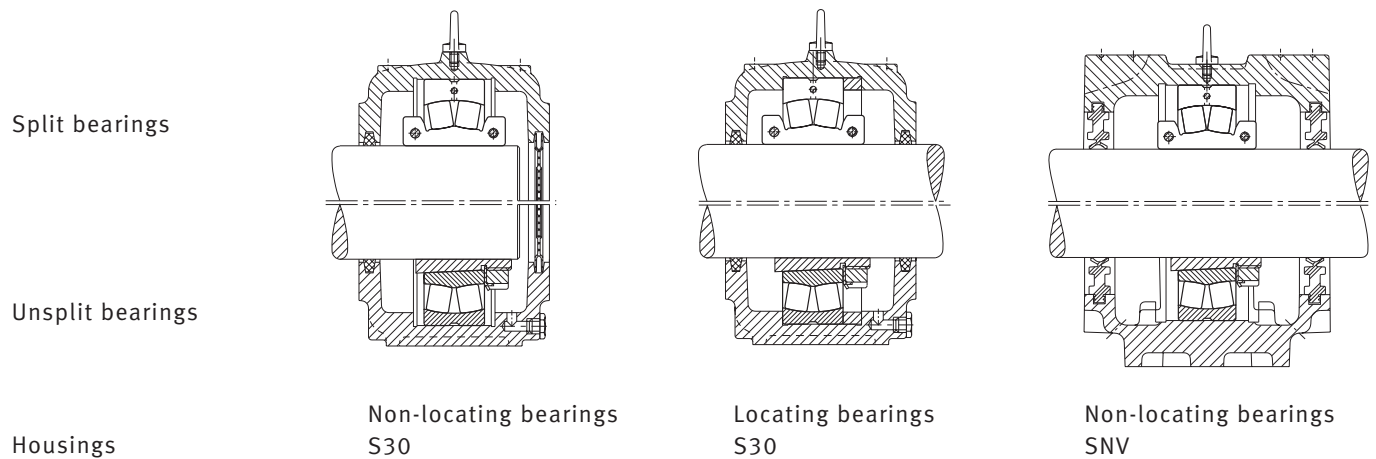

Designation	Permissible axial load ^{*)} F_a max. kN	Limiting speed n_G min^{-1}	Screw tightening torque		Replacement for unsplit spherical roller bearings with adapter sleeve		Suitable plummer block housings ^{**)} FAG
			M_i N m	M_a N m	Bearing	Adapter sleeve	
222SM55-TVPA	5,4	3 000	8,5	1,5	22212K	H312	SNV110 ¹⁾
222SM60-TVPA	5,4	2 800	8,5	4	22213K	H313	SNV120 ¹⁾
222SM65-TVPA	5,4	2 400	8,5	4	22215K	H315	SNV130 ¹⁾
222SM70-TVPA	5,4	2 400	8,5	4,1	22216K	H316	SNV140 ¹⁾
222SM75-TVPA	7,6	2 200	14	8,5	22217K	H317	SNV150 ¹⁾
222SM80-TVPA	7,6	2 000	14	8,5	22218K	H318	SNV160 ¹⁾
222SM85-TVPA	7,6	1 900	14	8,5	22219K	H319	SNV170 ¹⁾
222SM90-TVPA	7,6	1 700	14	14	22220K	H320	SNV180 ¹⁾
231SM100-MA	7,6	1 100	14	4	23122K	H3122	–
222SM100-TVPA	13,8	1 500	35	14	22222K	H322	SNV200 ¹⁾
230SM110-MA	7,6	1 100	14	4	23024K	H3024	S3024-H-N-FZ ¹⁾
231SM110-MA	14	1 000	35	8	23124K	H3124	–
222SM110-TVPA	13,8	1 300	35	14	22224K	H3124	SNV215
230SM115-MA	7,6	1 100	14	8,5	23026K	H3026	S3026-H-N-FZ ¹⁾
231SM115-MA	7,6	900	14	4	23126K	H3126	–
222SM115-TVPA	13,8	1 200	35	14	22226K	H3126	SNV230
230SM125-MA	7,6	950	14	4	23028K	H3028	S3028-H-N-FZ ¹⁾
231SM125-MA	13,8	850	35	8,5	23128K	H3128	–
222SM125-TVPA	13,8	1 100	35	14	22228K	H3128	SNV250
230SM135-MA	13,8	950	35	8,5	23030K	H3030	S3030-H-N-FZ ¹⁾
231SM135-MA	22,2	800	69	14	23130K	H3130	–
222SM135-TVPA	22,2	1 000	69	35	22230K	H3130	SNV270
230SM140-MA	13,8	900	35	8,5	23032K	H3032	S3032-H-N-FZ ¹⁾
231SM140-MA	21,7	700	69	12,4	23132K	H3132	–
222SM140-TVPA	22,2	950	69	35	22232K	H3132	SNV290

^{*)} For inner rings without axial support

^{**)} The bearings will also fit in housings from other manufacturers if the internal dimensions are identical.
Seals, covers and locating rings for SNV housings: see Catalogue HR 1, Rolling Bearings.

¹⁾ Housing without eye bolt

FAG Spherical roller bearings

Split, in metric sizes

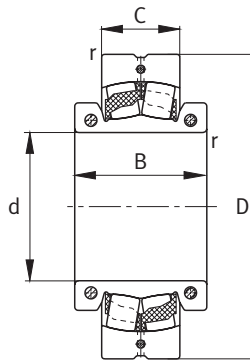
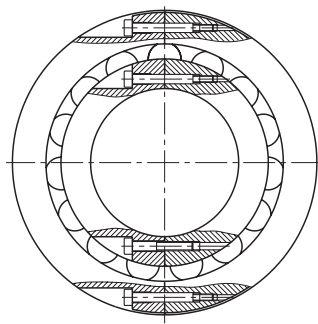

Solid polyamide cage
TVPA

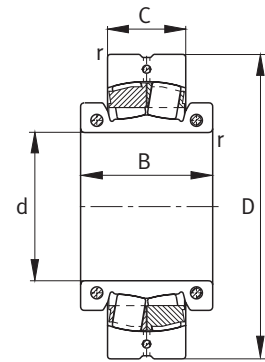

Solid brass cage
MA

Dimension table · Dimensions in mm

Designation	Mass m ≈kg	Dimensions					Basic load ratings			Calculation factors				Fatigue limit load C _{ur} kN
		d	D	C	B	r	dyn. C _r min. kN	stat. C _{0r} kN	e	Y ₁	Y ₂	Y ₀		
													D	
230SM150-MA	17,4	150	260	67	112	2,1	510	800	0,22	3,1	4,62	3,03	57	
231SM150-MA	28	150	280	88	133	2,1	710	1040	0,29	2,32	3,45	2,26	87	
222SM150-TVPA	35,5	150	310	86	128	4	965	1370	0,26	2,64	3,93	2,58	94	
230SM160-MA	24,4	160	280	74	123	2,1	640	1000	0,23	2,98	4,44	2,92	96	
231SM160-MA	32,7	160	300	96	140	2,1	830	1220	0,29	2,32	3,45	2,26	100	
222SM160-TVPA	37,6	160	320	86	131	4	965	1370	0,26	2,64	3,93	2,58	94	
230SM170-MA	23,6	170	290	75	120	2,1	780	1250	0,23	2,9	4,31	2,83	113	
231SM170-MA	40,6	170	320	104	142	2,1	915	1430	0,28	2,37	3,53	2,32	114	
222SM170-TVPA	43,6	170	340	92	142	4	1140	1630	0,25	2,71	4,04	2,65	111	
230SM180-MA	30	180	310	82	134	2,1	800	1270	0,23	2,98	4,44	2,92	115	
231SM180-MA	56,4	180	340	112	160	3	1020	1530	0,29	2,32	3,45	2,26	119	
222SM180-MA	52,7	180	360	98	154	4	1140	1630	0,25	2,71	4,04	2,65	104	
230SM200-MA	45	200	340	90	136	3	965	1530	0,23	2,9	4,31	2,83	136	
231SM200-MA	61,8	200	370	120	175	4	1320	2040	0,31	2,21	3,29	2,16	151	
222SM200-MA	69,6	200	400	108	162	4	1340	1900	0,25	2,69	4	2,63	121	
230SM220-MA	42,6	220	360	92	156	3	1100	1830	0,23	2,9	4,31	2,83	152	
231SM220-MA	86	220	400	128	190	4	1630	2600	0,3	2,25	3,34	2,2	191	
222SM220-MA	90,9	220	440	120	170	4	1460	2080	0,25	2,71	4,04	2,65	126	
230SM240-MA	57,4	240	400	104	160	4	1220	2120	0,22	3,04	4,53	2,97	177	
231SM240-MA	118	240	440	144	210	4	1860	3050	0,3	2,28	3,39	2,23	218	
222SM240-MA	136	240	480	130	200	5	1860	2600	0,26	2,64	3,93	2,58	157	
230SM260-MA	63,6	260	420	106	170	4	1460	2450	0,23	2,95	4,4	2,89	200	
231SM260-MA	109	260	460	146	190	5	2280	3800	0,3	2,23	3,32	2,18	255	
222SM260-MA	147	260	500	130	200	5	2200	3100	0,25	2,67	3,97	2,61	182	
230SM280-MA	96	280	460	118	176	4	1600	2800	0,22	3,04	4,53	2,97	228	
231SM280-MA	160	280	500	160	218	5	2320	3900	0,29	2,32	3,45	2,26	265	
222SM280-MA	157	280	540	140	200	5	2400	3550	0,24	2,79	4,15	2,73	212	
230SM300-MA	108	300	480	121	186	4	1860	3200	0,23	2,9	4,31	2,83	255	
231SM300-MA	184	300	540	176	225	5	2750	4750	0,29	2,3	3,42	2,25	305	
222SM300-MA	214	300	580	150	212	5	2650	4050	0,24	2,84	4,23	2,78	228	

Other designs are also available; please contact us.

Equivalent dynamic load

$$P = 1,1 (F_r + Y_1 \cdot F_a) \quad [\text{kN}] \quad F_a/F_r \leq e$$

$$P = 1,1 (0,67 \cdot F_r + Y_2 \cdot F_a) \quad [\text{kN}] \quad F_a/F_r > e$$

Equivalent static load

$$P_0 = F_{0r} + Y_0 \cdot F_{0a} \quad [\text{kN}]$$

In order to prevent creep of the inner rings in a circumferential direction on the shaft, P/C₀ must be ≤ 0,2. Higher values are permissible if the actual speed is significantly lower than the limiting speed. In such cases, please contact us.

Examples of bearing replacement in plummer block housings

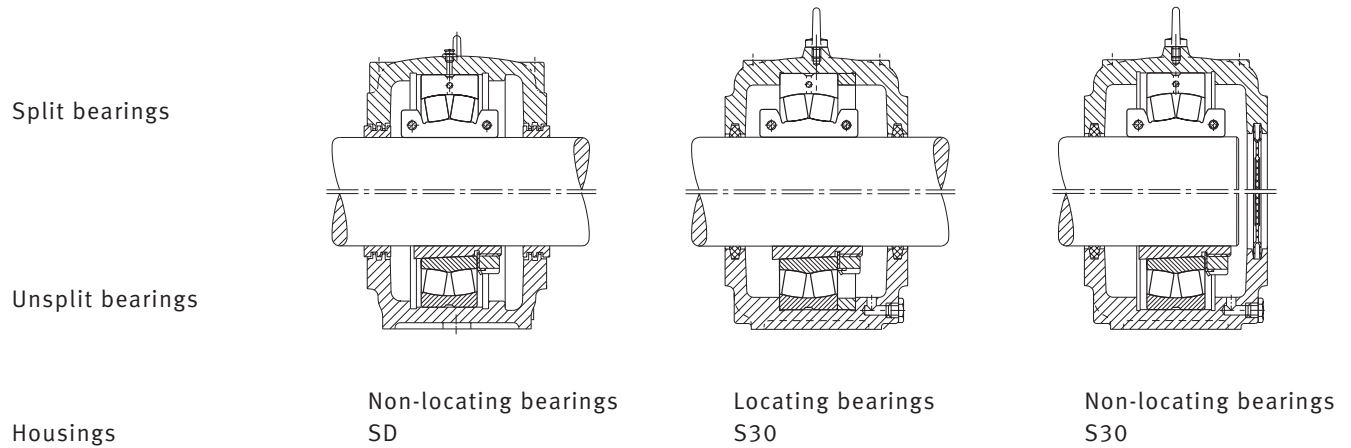

Designation	Permissible axial load ^{*)} F_a max. kN	Limiting speed n_G min^{-1}	Screw tightening torque		Replacement for unsplit spherical roller bearings with adapter sleeve		Suitable plummer block housings ^{**)} FAG
			M_i N m	M_a N m	Bearing	Adapter sleeve	
230SM150-MA	13,8	800	35	8,5	23034K	H3034	S3034-H-N-FZ
231SM150-MA	22	700	69	35	23134K	H3134	SD3134-H-TS
222SM150-TVPA	22,2	900	69	35	22234K	H3134	SD534-N-FZ
230SM160-MA	22,2	750	69	14	23036K	H3036	S3036-H-N-FZ
231SM160-MA	22	670	69	35	23136K	H3136	SD3136-H-TS
222SM160-TVPA	22,2	900	69	35	22236K	H3136	SD536-N-FZ
230SM170-MA	22,2	700	69	14	23038K	H3038	S3038-H-N-FZ
231SM170-MA	22	630	69	35	23138K	H3138	SD3138-H-TS
222SM170-TVPA	22,2	800	69	35	22238K	H3138	SD538-N-FZ
230SM180-MA	22	670	69	14	23040K	H3040	S3040-H-N-FZ
231SM180-MA	22	600	69	35	23140K	H3140	SD3140-H-TS
222SM180-MA	22,2	600	69	35	22240K	H3140	SD540-N-FZ
230SM200-MA	22	630	69	35	23044K	H3044X	S3044-H-N-FZ
231SM200-MA	32	530	120	69	23144K	H3144X	SD3144-H-TS
222SM200-MA	32	560	120	69	22244K	H3144X	SD544-N-FZ
230SM220-MA	32	560	120	35	23048K	H3048	S3048-H-N-FZ
231SM220-MA	32	480	120	69	23148K	H3148X	SD3148-H-TS
222SM220-MA	32	500	120	69	22248K	H3148X	SD548-N-FZ
230SM240-MA	32	560	120	69	23052K	H3052	S3052-H-N-FZ
231SM240-MA	32	450	120	69	23152K	H3152X	SD3152-H-TS
222SM240-MA	60	450	295	120	22252K	H3152X	SD552-N-FZ
230SM260-MA	32	500	120	35	23056K	H3056	S3056-H-N-FZ
231SM260-MA	32	400	120	35	23156K	H3156X	SD3156-H-TS
222SM260-MA	60	430	295	69	22256K	H3156X	SD556-N-FZ
230SM280-MA	32	480	120	69	23060K	H3060	S3060-H-N-FZ
231SM280-MA	44	400	190	120	23160K	H3160HG	SD3160-H-TS
222SM280-MA	60	430	295	120	22260K	H3160HG	SD560-N-FZ
230SM300-MA	32	430	120	69	23064K	H3064HG	S3064-H-N-FZ
231SM300-MA	60	360	295	120	23164K	H3164HG	SD3164-H-TS
222SM300-MA	60	380	295	120	22264K	H3164HG	SD564-N-FZ

^{*)} For inner rings without axial support

^{**)} The bearings will also fit in housings from other manufacturers if the internal dimensions are identical.

FAG Spherical roller bearings

Split, in metric sizes

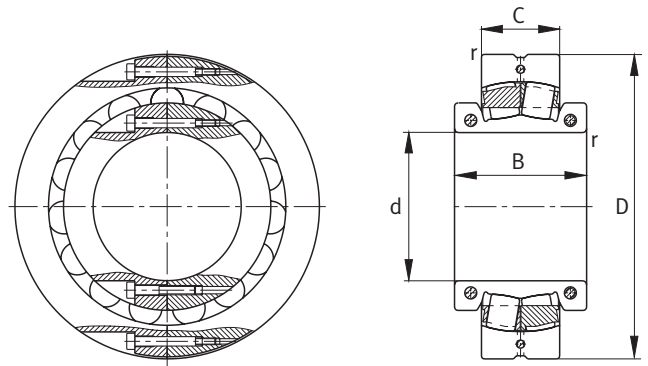

Solid brass cage
MA

Dimension table · Dimensions in mm

Designation	Mass	Dimensions					Basic load ratings		Calculation factors				Fatigue limit load
		m	d	D	C	B	r	dyn. C_r	stat. C_{0r}	e	Y_1	Y_2	Y_0
	≈kg					min.	kN	kN					kN
230SM320-MA	122	320	520	133	200	5	2 040	3 650	0,22	3,04	4,53	2,97	285
231SM320-MA	226	320	580	190	258	5	3 100	5 200	0,3	2,26	3,37	2,21	325
222SM320-MA	245	320	620	165	230	6	3 100	4 750	0,24	2,76	4,11	2,7	270
230SM340-MA	150	340	540	134	205	5	2 360	4 150	0,22	3,01	4,48	2,94	315
231SM340-MA	314	340	600	192	270	5	3 900	6 800	0,3	2,25	3,34	2,2	410
222SM340-MA	267	340	650	170	240	6	3 450	5 100	0,25	2,69	4	2,63	280
230SM360-MA	165	360	560	135	218	5	2 550	4 650	0,22	3,1	4,62	3,03	350
231SM360-MA	292	360	620	194	270	5	3 900	6 950	0,3	2,28	3,39	2,23	420
230SM380-MA	187	380	600	148	225	5	2 700	5 100	0,21	3,2	4,77	3,13	390
231SM380-MA	326	380	650	200	270	6	4 050	7 200	0,28	2,39	3,56	2,34	440
230SM400-MA	214	400	620	150	225	5	3 100	5 700	0,22	3,1	4,62	3,03	420
231SM400-MA	371	400	700	224	285	6	4 400	7 650	0,28	2,39	3,56	2,34	480
230SM410-MA	246	410	650	157	225	5	3 100	5 850	0,21	3,2	4,77	3,13	425
230SM420-MA	246	420	650	157	235	5	3 100	5 850	0,21	3,2	4,77	3,13	425

Other designs are also available; please contact us.

Equivalent dynamic load

$$P = 1,1 (F_r + Y_1 \cdot F_a) \quad [\text{kN}] \quad F_a/F_r \leq e$$

$$P = 1,1 (0,67 \cdot F_r + Y_2 \cdot F_a) \quad [\text{kN}] \quad F_a/F_r > e$$

Equivalent static load

$$P_0 = F_{0r} + Y_0 \cdot F_{0a} \quad [\text{kN}]$$

In order to prevent creep of the inner rings in a circumferential direction on the shaft, P/C_r must be $\leq 0,2$. Higher values are permissible if the actual speed is significantly lower than the limiting speed. In such cases, please contact us.

Examples of bearing replacement in plummer block housings

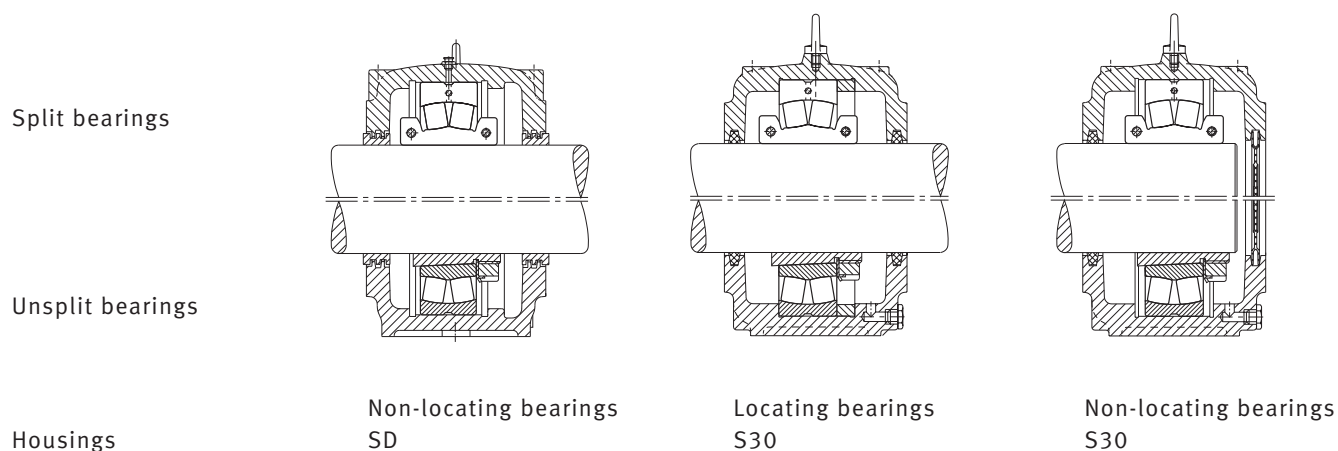

Designation	Permissible axial load ^{*)} F_a max. kN	Limiting speed n_G min^{-1}	Screw tightening torque		Replacement for unsplit spherical roller bearings with adapter sleeve		Suitable plummer block housings ^{**)} FAG
			M_i N m	M_a N m	Bearing	Adapter sleeve	
230SM320-MA	60	430	295	69	23068K	H3068HG	S3068-H-N-FZ
231SM320-MA	60	340	295	190	23168K	H3168HG	SD3168-H-TSTS
222SM320-MA	60	360	295	120	22268K	H3168HG	–
230SM340-MA	60	380	295	69	23072K	H3072HG	S3072-H-N-FZ
231SM340-MA	60	300	295	70	23172K	H3172HG	SD3172-H-TS
222SM340-MA	60	340	295	120	22272K	H3172HG	–
230SM360-MA	60	380	295	69	23076K	H3076HG	S3076-H-N-FZ
231SM360-MA	60	300	295	69	23176K	H3176HG	SD3176-H-TS
230SM380-MA	60	380	295	120	23080K	H3080HG	S3080-H-N-FZ
231SM380-MA	60	300	295	120	23180K	H3180HG	SD3180-H-TS
230SM400-MA	60	340	295	69	23084K	H3084XHG	S3084-H-N-FZ
231SM400-MA	60	280	295	190	23184K	H3184HG	SD3184-H-TS
230SM410-MA	60	340	295	120	23088K	H3088HG	S3088-H-N-FZ
230SM420-MA	60,5	340	295	120	23088K	AHX3088GH ¹⁾	–

^{*)} For inner rings without axial support

^{**)} The bearings will also fit in housings from other manufacturers if the internal dimensions are identical.

¹⁾ Extraction sleeve

FAG Spherical roller bearings

Split, in inch sizes

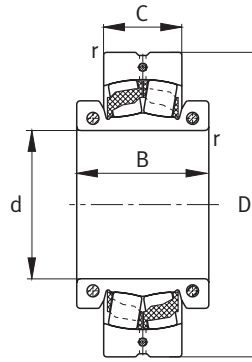
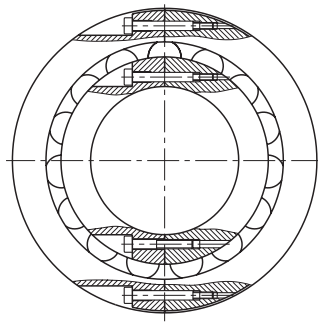

Solid polyamide cage

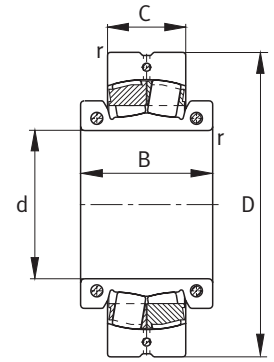

Solid brass cage
MA

Dimension table · Dimensions in mm

Designation	Mass m ≈kg	Dimensions						Basic load ratings		Calculation factors			Fatigue limit load C _{ur} kN	
		d inch	D mm	C mm	B mm	r mm	dyn. C _r kN	stat. C _{0r} kN	e	Y ₁	Y ₂	Y ₀		
222S.203	1,99	2,1875	55,563	120	31	55	1,5	137	156	0,23	2,98	4,44	2,92	15,4
222S.204	1,98	2,2500	57,15	120	31	55	1,5	137	156	0,23	2,98	4,44	2,92	15,4
222S.207	2,45	2,4375	61,913	130	31	60	1,5	173	208	0,24	2,81	4,19	2,75	19,4
222S.208	2,41	2,5000	63,5	130	31	60	1,5	173	208	0,24	2,81	4,19	2,75	19,4
222S.211	3	2,6875	68,263	140	33	62	2	180	228	0,23	2,95	4,4	2,89	21,1
222S.215	3,58	2,9375	74,613	150	36	68	2	183	236	0,22	3,1	4,62	3,03	22,5
222S.300	3,53	3,0000	76,2	150	36	68	2	183	236	0,22	3,1	4,62	3,03	22,5
222S.303	4,22	3,1875	80,963	160	40	70	2	212	270	0,22	3,14	4,67	3,07	25,5
222S.304	4,1	3,2500	82,55	160	40	70	2	212	270	0,22	3,14	4,67	3,07	25,5
222S.307	6,86	3,4375	87,313	180	46	76	2,1	285	360	0,23	2,9	4,31	2,83	32,5
222S.307-MA	6,98	3,4375	87,313	180	46	76	2,1	260	320	0,23	2,9	4,31	2,83	28,5
222S.308	6,77	3,5000	88,9	180	46	76	2,1	285	360	0,23	2,9	4,31	2,83	32,5
222S.308-MA	6,86	3,5000	88,9	180	46	76	2,1	260	320	0,23	2,9	4,31	2,83	28,5
222S.315	8,88	3,9375	100,013	200	53	92	2,1	360	465	0,24	2,84	4,23	2,78	39,5
222S.400	8,83	4,0000	101,6	200	53	92	2,1	360	465	0,24	2,84	4,23	2,78	39,5
222S.403	11	4,1875	106,363	215	58	98	2,1	455	585	0,25	2,71	4,04	2,65	47
222S.407	14,7	4,4375	112,713	230	64	104	3	540	720	0,25	2,71	4,04	2,65	53
222S.408	14,4	4,5000	114,3	230	64	104	3	540	720	0,25	2,71	4,04	2,65	53
222S.415	17,8	4,9375	125,413	250	68	110	3	630	880	0,26	2,62	3,9	2,56	60
222S.415-MA	17,9	4,9375	125,413	250	68	110	3	585	780	0,26	2,62	3,9	2,56	53
222S.500	17,5	5,0000	127	250	68	110	3	630	880	0,26	2,62	3,9	2,56	60
222S.503	25,2	5,1875	131,763	270	73	122	3	735	1020	0,25	2,67	3,97	2,61	73
222S.507	28,9	5,4375	138,113	290	80	124	3	850	1200	0,25	2,69	4	2,63	83
222S.507-MA	31,3	5,4375	138,113	290	80	124	3	780	1060	0,25	2,69	4	2,63	74
230S.508-MA	13,7	5,5000	139,7	240	60	106	2,1	450	680	0,22	3,1	4,62	3,03	51
222S.508	28,6	5,5000	139,7	290	80	124	3	850	1200	0,25	2,69	4	2,63	83

Other designs are also available; please contact us.

Equivalent dynamic load

$$P = 1,1 (F_r + Y_1 \cdot F_a) \quad [\text{kN}] \quad F_a/F_r \leq e$$

$$P = 1,1 (0,67 \cdot F_r + Y_2 \cdot F_a) \quad [\text{kN}] \quad F_a/F_r > e$$

Equivalent static load

$$P_0 = F_{0r} + Y_0 \cdot F_{0a} \quad [\text{kN}]$$

In order to prevent creep of the inner rings in a circumferential direction on the shaft, P/C_r must be $\leq 0,2$. Higher values are permissible if the actual speed is significantly lower than the limiting speed. In such cases, please contact us.

Examples of bearing replacement in plummer block housings

Split bearings

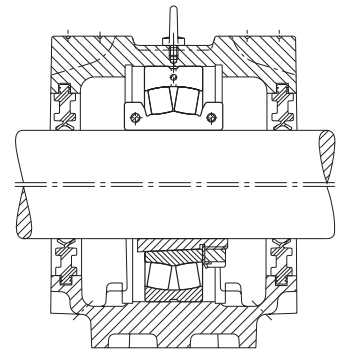
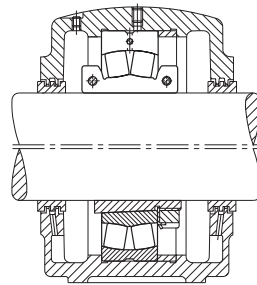
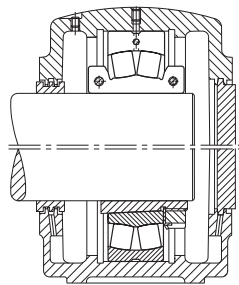

Unsplit bearings

Housings

Non-locating bearings
SAF

Locating bearings
SAF

Non-locating bearings
SNV

Designation	Permissible axial load ^{*)} F _a max. kN	Limiting speed n _G min ⁻¹	Screw tightening torque		Replacement for unsplit spherical roller bearings with adapter sleeve			Suitable plummer block housings ^{**)}	
			M _i N m	M _a N m	Bearing	Adapter sleeve	Adapter sleeve	FAG	FAG
222S.203	5,4	2 800	8,5	1,5	22213K	SNW13.203	H313.203	SAF513	SNV120 ¹⁾
222S.204	5,4	2 800	8,5	1,5	22213K	SNW13.204	H313.204	SAF513/2.1/4	SNV120 ¹⁾
222S.207	5,4	2 400	8,5	4	22215K	SNW15.207	H315.207	SAF515	SNV130 ¹⁾
222S.208	5,4	2 400	8,5	4	22215K	SNW15.208	H315.208	SAF515/2.1/2	SNV130 ¹⁾
222S.211	5,4	2 400	8,5	4	22216K	SNW16.211	H316.211	SAF516	SNV140 ¹⁾
222S.215	7,6	2 200	14	8,5	22217K	SNW17.215	H317.215	SAF517	SNV150 ¹⁾
222S.300	7,6	2 200	14	8,5	22217K	SNW17.300	H317.300	SAF517/3	SNV150 ¹⁾
222S.303	7,6	2 000	14	8,5	22218K	SNW18.303	H318.303	SAF518	SNV160 ¹⁾
222S.304	7,6	2 000	14	8,5	22218K	SNW18.304	H318.304	SAF518/3.1/4	SNV160 ¹⁾
222S.307	7,6	1 700	14	14	22220K	SNW20.307	H320.307	SAF520	SNV180 ¹⁾
222S.307-MA	7,6	1 300	14	14	22220K	SNW20.307	H320.307	SAF520	SNV180 ¹⁾
222S.308	7,6	1 700	14	14	22220K	SNW20.308	H320.308	SAF520/3.1/2	SNV180 ¹⁾
222S.308-MA	7,6	1 300	14	14	22220K	SNW20.308	H320.308	SAF520/3.1/2	SNV180 ¹⁾
222S.315	13,8	1 500	35	14	22222K	SNW22.315	H322.315	SAF522	SNV200 ¹⁾
222S.400	13,8	1 500	35	14	22222K	SNW22.400	H322.400	SAF522/4	SNV200 ¹⁾
222S.403	13,8	1 300	35	14	22224K	SNW24.403	H3124.403	SAF524	SNV215
222S.407	13,8	1 200	35	14	22226K	SNW26.407	H3126.407	SAF526	SNV230
222S.408	13,8	1 200	35	14	22226K	SNW26.408	H3126.408	SAF526/4.1/2	SNV230
222S.415	13,8	1 100	35	14	22228K	SNW28.415	H3128.415	SAF528	SNV250
222S.415-MA	13,8	850	35	14	22228K	SNW28.415	H3128.415	SAF528	SNV250
222S.500	13,8	1 100	35	14	22228K	SNW28.500	H3128.500	SAF528/5	SNV250
222S.503	22,2	1 000	69	35	22230K	SNW30.503	H3130.503	SAF530	SNV270
222S.507	22,2	950	69	35	22232K	SNW32.507	H3132.507	SAF532	SNV290
222S.507-MA	22,2	750	69	35	22232K	SNW32.507	H3132.507	SAF532	SNV290
230S.508-MA	13,8	900	35	8,5	23032K	SNP3032.508	H3032.508	SAF032K/5.1/2	–
222S.508	22,2	950	69	35	22232K	SNW32.508	H3132.508	SAF532/5.1/2	SNV290

^{*)} For inner rings without axial support

^{**)} The bearings will also fit in housings from other manufacturers if the internal dimensions are identical.
Seals, covers and locating rings for SNV housings: see Catalogue HR 1, Rolling Bearings.

¹⁾ Housing without eye bolt

FAG Spherical roller bearings

Split, in inch sizes

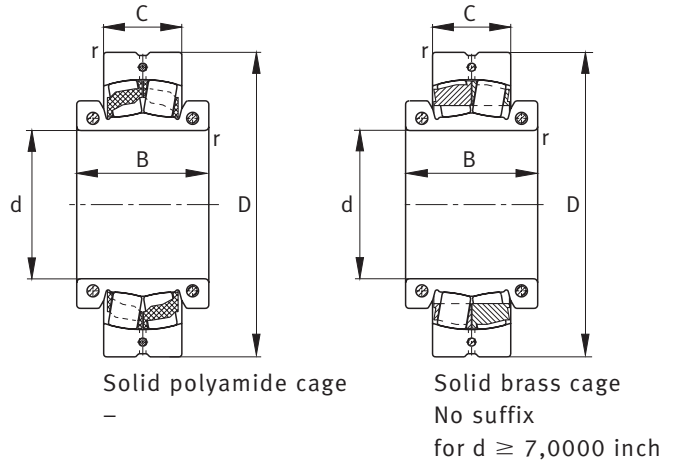
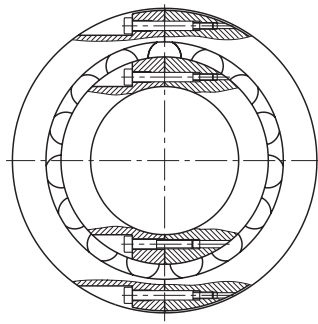

Dimension table · Dimensions in mm

Designation	Mass m ≈kg	Dimensions						Basic load ratings		Calculation factors				Fatigue limit load C _{ur} kN
		d inch	D mm	C mm	B mm	r mm	dyn. C _r min. kN	stat. C _{0r} kN	e	Y ₁	Y ₂	Y ₀		
222S.515	35,5	5,9375	150,813	310	86	128	4	965	1370	0,26	2,64	3,93	2,58	94
222S.600	36,5	6,0000	152,4	310	86	128	4	965	1370	0,26	2,64	3,93	2,58	94
230S.607-MA	24,4	6,4375	163,513	280	74	123	2,1	640	1000	0,23	2,98	4,44	2,92	96
231S.607-MA	34,4	6,4375	163,513	300	96	140	2,1	830	1220	0,29	2,32	3,45	2,26	100
222S.607	37,5	6,4375	163,513	320	86	131	4	965	1370	0,26	2,64	3,93	2,58	94
222S.608	37,8	6,5000	165,1	320	86	131	4	965	1370	0,26	2,64	3,93	2,58	94
222S.615	44,2	6,9375	176,213	340	92	142	4	1140	1630	0,25	2,71	4,04	2,65	111
230S.700	21,1	7,0000	177,8	290	75	120	2,1	780	1250	0,23	2,9	4,31	2,83	113
222S.703	59	7,1875	182,563	360	98	154	4	1140	1630	0,25	2,71	4,04	2,65	104
222S.708	73,3	7,5000	190,5	400	108	162	4	1340	1900	0,25	2,69	4	2,63	121
222S.715	75,4	7,9375	201,613	400	108	162	4	1340	1900	0,25	2,69	4	2,63	121
222S.800	74,7	8,0000	203,2	400	108	162	4	1340	1900	0,25	2,69	4	2,63	121
230S.807	54,7	8,4375	214,313	360	92	156	3	1100	1830	0,23	2,9	4,31	2,83	152
230S.808	58,9	8,5000	215,9	360	92	156	3	1100	1830	0,23	2,9	4,31	2,83	152
230S.900	52,8	9,0000	228,6	360	92	156	3	1100	1830	0,23	2,9	4,31	2,83	152
231S.907	113	9,4375	239,713	440	144	210	4	1860	3050	0,3	2,28	3,39	2,23	218
230S.908	56,8	9,5000	241,3	400	104	160	4	1220	2120	0,22	3,04	4,53	2,97	177
231S.915	116	9,9375	260	460	146	190	5	2280	3800	0,3	2,23	3,32	2,18	255
230S.1000	71,2	10,0000	254	420	106	170	4	1460	2450	0,23	2,95	4,4	2,89	200
230S.1008	59,7	10,5000	266,7	420	106	170	4	1460	2450	0,23	2,95	4,4	2,89	200
230S.1100	91,7	11,0000	279,4	460	118	176	4	1600	2800	0,22	3,04	4,53	2,97	228
231S.1100	160	11,0000	279,4	500	160	218	5	2320	3900	0,29	2,32	3,45	2,26	265
230S.1200	96,5	12,0000	304,8	480	121	186	4	1860	3200	0,23	2,9	4,31	2,83	255
231S.1200	184	12,0000	304,8	540	176	225	5	2750	4750	0,29	2,3	3,42	2,25	305

Other designs are also available; please contact us.

Equivalent dynamic load

$$P = 1,1 (F_r + Y_1 \cdot F_a) \quad [\text{kN}] \quad F_a/F_r \leq e$$

$$P = 1,1 (0,67 \cdot F_r + Y_2 \cdot F_a) \quad [\text{kN}] \quad F_a/F_r > e$$

Equivalent static load

$$P_0 = F_{0r} + Y_0 \cdot F_{0a} \quad [\text{kN}]$$

In order to prevent creep of the inner rings in a circumferential direction on the shaft, P/C_r must be $\leq 0,2$. Higher values are permissible if the actual speed is significantly lower than the limiting speed. In such cases, please contact us.

Examples of bearing replacement in plummer block housings

Split bearings

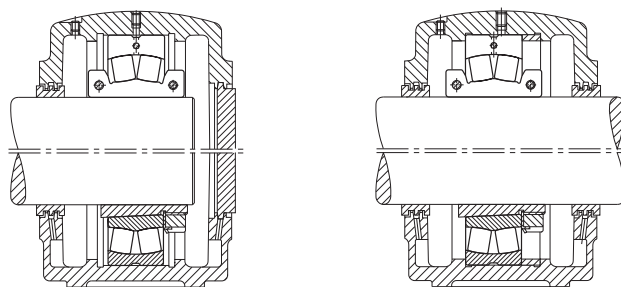

Unsplit bearings

Non-locating bearings
SAF, SDAF

Locating bearings
SAF, SDAF

Housings

Designation	Permissible axial load ^{*)} F _a max. kN	Limiting speed n _G min ⁻¹	Screw tightening torque		Replacement for unsplit spherical roller bearings with adapter sleeve			Suitable plummer block housings ^{**)} FAG
			M _i N m	M _a N m	Bearing	Adapter sleeve	Adapter sleeve	
222S.515	22,2	900	69	35	22234K	SNW34.515	H3134.515	SAF534
222S.600	22,2	900	69	35	22234K	SNW34.600	H3134.600	SAF534/6
230S.607-MA	22,2	750	69	14	23038K	SNP3036.607	H3038.607	SAF038K/6.7/16
231S.607-MA	22,2	670	69	35	23136K	SNP3136.607	H3136.607	SDAF3136K/6.7/16
222S.607	22,2	900	69	35	22236K	SNW36.607	H3136.607	SAF536
222S.608	22,2	900	69	35	22236K	SNW36.608	H3136.608	SAF536/6.1/2
222S.615	22,2	800	69	35	22238K	SNW38.615	H3138.615	SAF538
230S.700	22,2	700	69	14	23038K	SNP3038.700	H3038.700	SAF038K/7
222S.703	22,2	600	69	35	22240K	SNW40.703	H3140.703	SAF540
222S.708	32	560	120	69	22244K	SNW44.708	H3144X.708	SAF544/7.1/2
222S.715	32	560	120	69	22244K	SNW44.715	H3144X.715	SAF544
222S.800	32	560	120	69	22244K	SNW44.800	H3144X.800	SAF544/8
230S.807	32	560	120	35	23048K	SNP3048.807	H3048.807	SAF048K/8.7/16
230S.808	32	560	120	35	23048K	SNP3048.808	H3048.808	SAF048K/8.1/2
230S.900	32	560	120	35	23048K	SNP3048.900	H3048.900	SAF048K/9
231S.907	32	450	120	69	23152K	SNP3152.907	H3152X.907	SDAF3152K/9.7/16
230S.908	32	560	120	69	23052K	SNP3052.908	H3052X.908	SAF052K/9.1/2
231S.915	32	400	120	35	23156K	SNP3156.915	H3156X.915	SDAF3156K/9.15/16
230S.1000	32	500	120	35	23056K	SNP3056.1000	H3056.1000	SAF056K/10
230S.1008	32	500	120	35	23056K	SNP3056.1008	H3056.1008	SAF056K/10.1/2
230S.1100	32	480	120	69	23060K	SNP3060.1100	H3060.1100	SDAF060K/11
231S.1100	44	400	190	120	23160K	SNP3160.1100	H3160HG.1100	SDAF3160K/11
230S.1200	32	430	120	69	23064K	SNP3064.1200	H3064HG.1200	SDAF064K/12
231S.1200	60	360	295	120	23164K	SNP3164.1200	H3164HG.1200	SDAF3164K/12

^{*)} For inner rings without axial support

^{**)} The bearings will also fit in housings from other manufacturers if the internal dimensions are identical.

FAG Spherical roller bearings

Split, in inch sizes

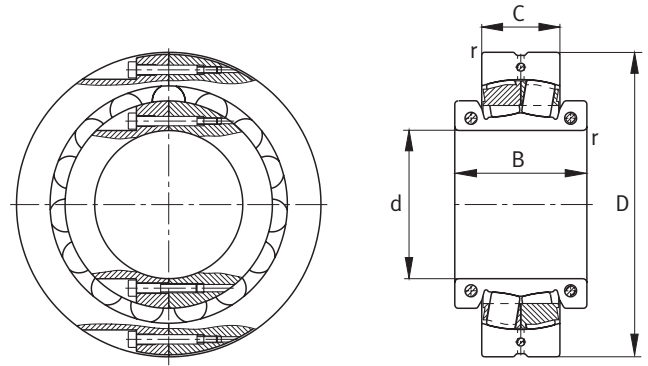

Solid brass cage

Dimension table · Dimensions in mm

Designation	Mass m	Dimensions		Basic load ratings					Calculation factors			Fatigue limit load C _{ur}		
		d	D	C	B	r	dyn. C _r	stat. C _{0r}	e	Y ₁	Y ₂		Y ₀	
		inch	mm	mm	mm	mm	min. kN	kN					kN	
230S.1300	165	13,0000	330,2	540	134	205	5	2 360	4 150	0,22	3,01	4,48	2,94	315
231S.1300	288	13,0000	330,2	600	192	270	5	3 900	6 800	0,3	2,25	3,34	2,2	410
230S.1400	158	14,0000	355,6	560	135	218	5	2 550	4 650	0,22	3,1	4,62	3,03	350
231S.1400	273	14,0000	355,6	620	194	270	5	3 900	6 950	0,3	2,28	3,39	2,23	420
230S.1500	192	15,0000	381	600	148	225	5	2 700	5 100	0,21	3,2	4,77	3,13	390
231S.1500	296	15,0000	381	650	200	270	6	4 050	7 200	0,28	2,39	3,56	2,34	440
230S.1600	225	16,0000	406,4	650	157	225	5	3 100	5 850	0,21	3,2	4,77	3,13	425
231S.1600 ¹⁾	547	16,0000	406,4	720	226	315	6	5 400	9 650	0,29	2,3	3,42	2,25	570

Other designs are also available; please contact us.

Equivalent dynamic load

$$P = 1,1 (F_r + Y_1 \cdot F_a) \quad [\text{kN}] \quad F_a/F_r \leq e$$

$$P = 1,1 (0,67 \cdot F_r + Y_2 \cdot F_a) \quad [\text{kN}] \quad F_a/F_r > e$$

Equivalent static load

$$P_0 = F_{0r} + Y_0 \cdot F_{0a} \quad [\text{kN}]$$

In order to prevent creep of the inner rings in a circumferential direction on the shaft, P/C_r must be $\leq 0,2$. Higher values are permissible if the actual speed is significantly lower than the limiting speed. In such cases, please contact us.

Examples of bearing replacement in plummer block housings

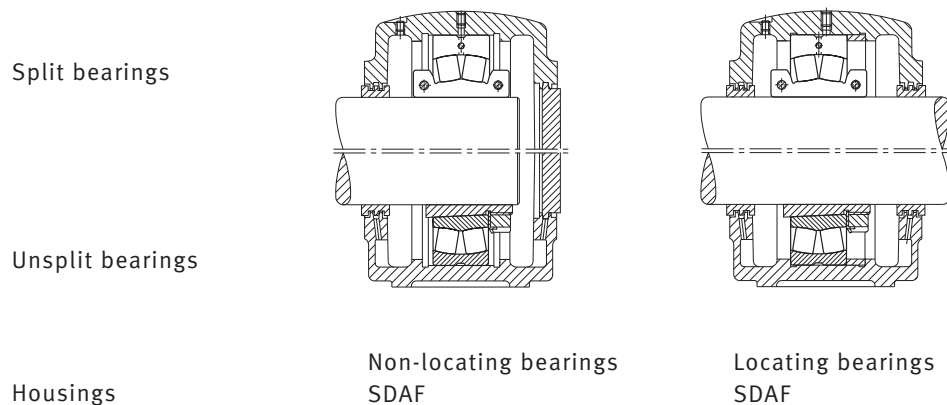

Designation	Permissible axial load ^{*)} F _a max. kN	Limiting speed n _G min ⁻¹	Screw tightening torque		Replacement for unsplit spherical roller bearings with adapter sleeve			Suitable plummer block housings ^{**)} FAG
			M _i N m	M _a N m	Bearing	Adapter sleeve	Adapter sleeve	
230S.1300	60	380	295	69	23072K	SNP3072.1300	H3072HG.1300	SDAF072K/13
231S.1300	60	300	295	35	23172K	SNP3172.1300	H3172HG.1300	SDAF3172K/13
230S.1400	60	380	295	69	23076K	SNP3076.1400	H3076HG.1400	SDAF076K/14
231S.1400	60	300	295	69	23176K	SNP3176.1400	H3176HG.1400	SDAF3176K/14
230S.1500	60	380	295	120	23080K	SNP3080.1500	H3080HG.1500	SDAF080K/15
231S.1500	60	300	295	120	23180K	SNP3180.1500	H3180HG.1500	SDAF3180K/15
230S.1600	60	340	295	120	23088K	SNP3088.1600	H3088HG.1600	SDAF088K/16
231S.1600 ¹⁾	94	260	580	120	23188K	SNP3188.1600	H3188HG.1600	SDAF3188K/16

^{*)} For inner rings without axial support

^{**)} The bearings will also fit in housings from other manufacturers if the internal dimensions are identical.

¹⁾ With locking collars

FAG Spherical roller bearings

Split, in metric sizes
With separate locking rings

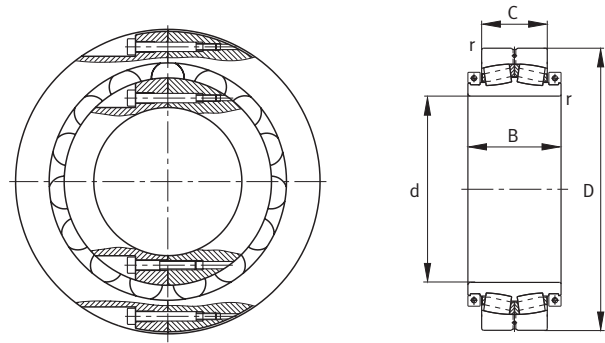

Solid brass cage
MA

Dimension table · Dimensions in mm

Designation	Mass m ≈kg	Dimensions					Basic load ratings		Calculation factors				Fatigue limit load
		d	D	C	B	r	dyn. C_r kN	stat. C_{0r} kN	e	Y_1	Y_2	Y_0	C_{ur} kN
						min.							
240SM400-MA	385	400	620	200	290	5	3 750	8 000	0,32	2,13	3,17	2,08	630
231SM410-MA	566	410	720	226	315	6	5 400	9 650	0,29	2,3	3,42	2,25	570
231SM430-MA	624	430	760	240	344	6	5 500	10 400	0,29	2,33	3,47	2,28	600
230SM450-MA	291	450	700	165	245	6	3 650	6 950	0,21	3,2	4,77	3,13	495
230SM470-MA	354	470	720	167	260	6	3 600	7 500	0,23	2,9	4,31	2,83	425
241SM470-MA	725	470	830	325	420	7,5	7 800	16 000	0,39	1,75	2,61	1,71	1 140
230SM500-MA	344	500	780	185	270	6	4 150	8 500	0,2	3,34	4,98	3,27	590
241SM500-MA	725	500	870	335	450	7,5	8 500	17 600	0,39	1,73	2,58	1,69	1 280
239SM530-MA	295	530	750	140	225	5	2 750	6 550	0,18	3,85	5,73	3,76	365
230SM530-MA	556	530	820	195	300	6	4 650	9 650	0,23	2,95	4,4	2,89	700
241SM530-MA	1 380	530	920	355	500	7,5	9 150	19 300	0,38	1,77	2,64	1,73	1 390
239SM560-MA	347	560	800	150	235	5	2 900	7 100	0,17	3,95	5,88	3,86	530
239SM600-MA	411	600	850	165	250	5	3 900	8 800	0,18	3,66	5,46	3,58	540
230SM630-MA	973	630	980	230	355	7,5	6 400	13 700	0,22	3,01	4,48	2,94	950

Other designs are also available; please contact us.

Equivalent dynamic load

$$P = 1,1 (F_r + Y_1 \cdot F_a) \quad [\text{kN}] \quad F_a/F_r \leq e$$

$$P = 1,1 (0,67 \cdot F_r + Y_2 \cdot F_a) \quad [\text{kN}] \quad F_a/F_r > e$$

Equivalent static load

$$P_0 = F_{0r} + Y_0 \cdot F_{0a} \quad [\text{kN}]$$

In order to prevent creep of the inner rings in a circumferential direction on the shaft, P/C_r must be $\leq 0,2$. Higher values are permissible if the actual speed is significantly lower than the limiting speed. In such cases, please contact us.

Examples of bearing replacement in plummer block housings

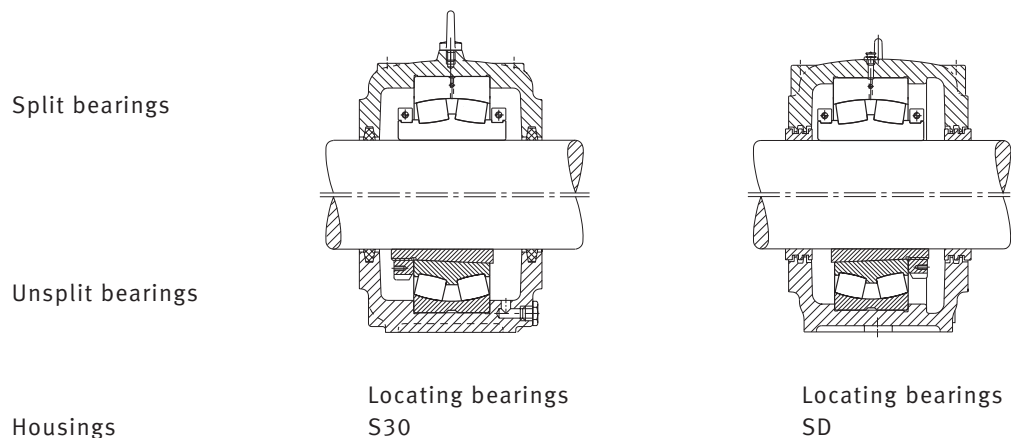

Designation	Permissible axial load ^{*)} F_a max. kN	Limiting speed n_G min^{-1}	Screw tightening torque		Replacement for unsplit spherical roller bearings with adapter sleeve		Suitable plummer block housings ^{**)} FAG
			M_i N m	M_a N m	Bearing	Adapter sleeve	
240SM400-MA	60	190	295	69	24084K30	H24084HG	–
231SM410-MA	60	260	295	120	23188K	H3188HG	SD3188-H-TS
231SM430-MA	94,2	300	580	295	23192K	H3192HG	–
230SM450-MA	60	300	190	190	23096K	H3096HG	S3096-H-N-FZ
230SM470-MA	60	190	295	120	230/500K	H30/500HG	–
241SM470-MA	60	530	1 000	295	241/500K30	H240/500HG	–
230SM500-MA	60	300	295	120	230/530K	H30/530HG	–
241SM500-MA	60	530	1 000	295	241/530K30	H240/530HG	–
239SM530-MA	60	170	295	69	239/560K	H39/560HG	–
230SM530-MA	94,2	160	580	120	230/560K	H30/560HG	–
241SM530-MA	135	500	2 000	295	241/560K30	H240/560HG	–
239SM560-MA	60	170	295	69	239/600K	H39/600HG	–
239SM600-MA	60	160	295	69	239/630K	H39/630HG	–
230SM630-MA	94,2	160	1 000	120	230/670K	H30/670HG	–

^{*)} For inner rings without axial support

^{**)} The bearings will also fit in housings from other manufacturers if the internal dimensions are identical.

Schaeffler KG

Georg-Schäfer-Strasse 30
97421 Schweinfurt (Germany)
Internet www.fag.com
E-mail FAGdirect@de.fag.com

In Germany:

Phone 0180 5003872
Fax 0180 5003873

From other countries:

Phone +49 9721 91-0
Fax +49 9721 91-3435

Every care has been taken to ensure the correctness of the information contained in this publication but no liability can be accepted for any errors or omissions.

We reserve the right to make technical modifications.

© Schaeffler KG · 2007, April

This publication or parts thereof may not be reproduced without our permission.

WL 43 165/3 EA