



Uhing Lineartriebe®
Uhing Linear Drives®



Rollringgetriebe
Rolling Ring Drives



Führungssystem
Guide System



Wälzmutter
Linear Drive Nut



Zahnriemenantriebe
Timing Belt Drive



Klemm- und Spannelemente
Clamping Systems



Verlegesysteme
Winding Systems

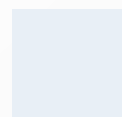
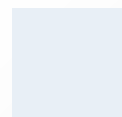
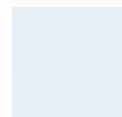
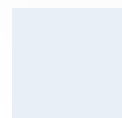

Uhing®-Führungssystem GS

Das **Uhing®-Führungssystem GS** überträgt die Hubbewegung der Verlegung auf Führungsrolle und Wickelgut. Es kann durch Zusatzbausteine universell an die Wickelaufgabe angepaßt werden.

Vorteile

- Modularer Aufbau für die einfache Anpassung an die Wickelaufgabe
- Stufenlos verstellbar
- Verwindungssteif
- Adapter zur Montage auf Uhing®- Rollringgetrieben der Baureihen KI bis RG30 lieferbar
- Komplett aus rostfreiem Edelstahl gefertigt
- Vielfältige Anbaumöglichkeit für Führungsrollen
- Für alle Verlegesysteme geeignet

Uhing® Guide System GS

The **Uhing® Guide System GS** transfers the movement of the traverse to the guide roller and the material to be wound. It can be universally adapted to the winding tasks using additional modules.

Advantages

- modular design for easy adaption to the winding task
- continuously adjustable
- high rigidity
- adapter for assembly on to Uhing® Rolling Ring Drives from KI to RG30 available
- made entirely of stainless steel
- versatile attachment options for guide rollers
- suited for all traversing systems

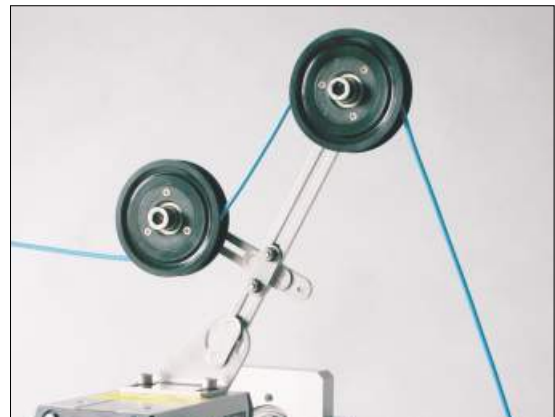
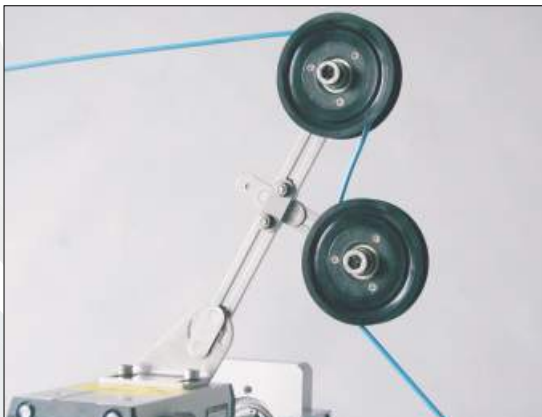
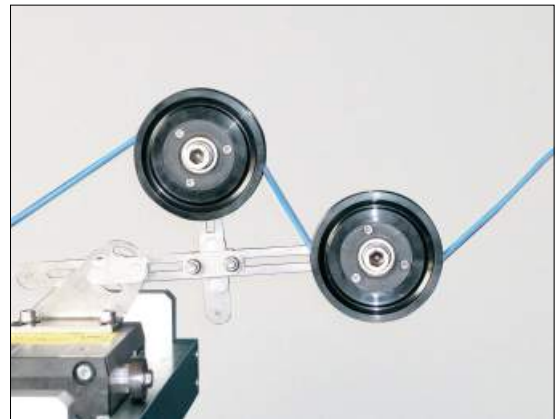
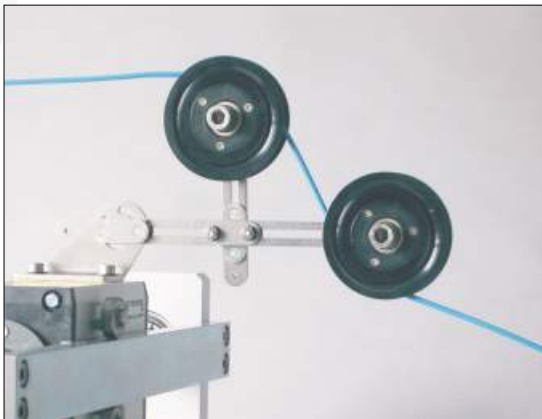

Anwendungsbeispiele / Examples of application



Technische Daten / Technical applications

Die Elemente des GS-Systems können vielfältig kombiniert werden.
The fastening devices of the GS system can be variably combined.

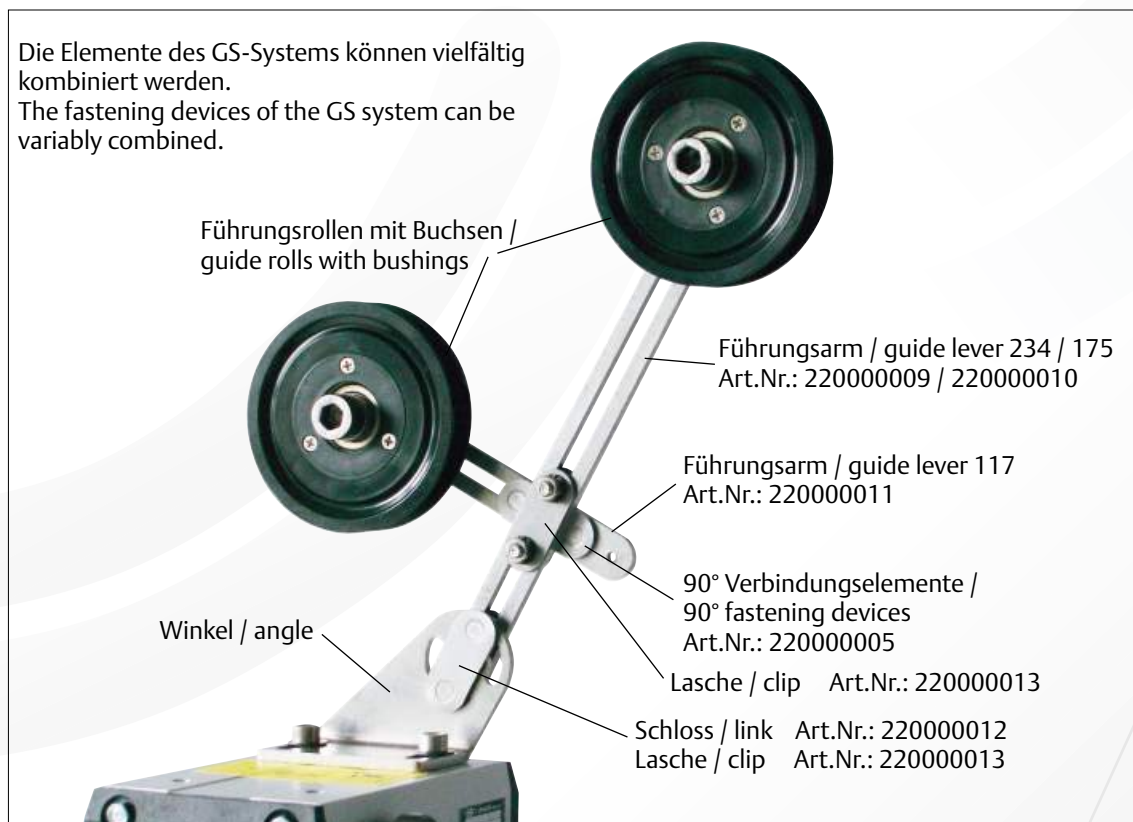

Technische Daten / Technical specifications

Führungsarm / Guide lever

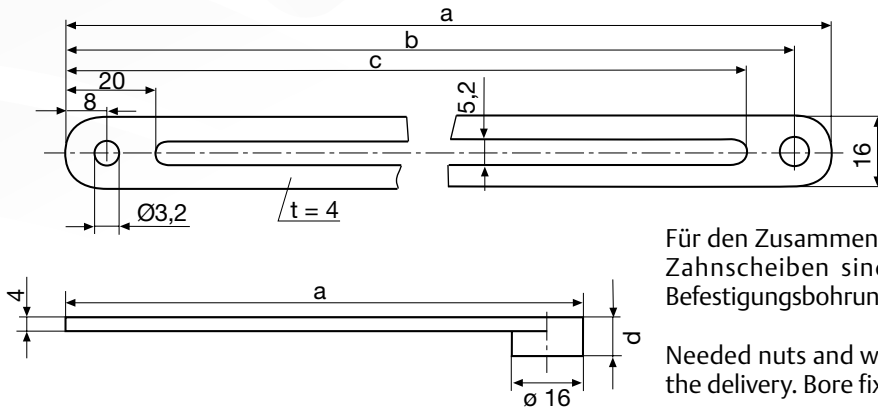

Für den Zusammenbau erforderliche Muttern und Zahnscheiben sind Bestandteil der Lieferung. Befestigungsbohrungen falls erforderlich aufbohren.

Needed nuts and washers for mounting belong to the delivery. Bore fixing holes if necessary.

Führungsarm / guide lever	a	b	c	d
für/for Art.Nr.: 220000009	234	226	214	÷
für/for Art.Nr.: 220000010	175	167	155	÷
für/for Art.Nr.: 220000011	117	109	97	10

Winkel / Angle

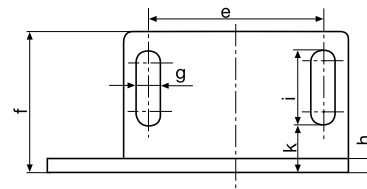
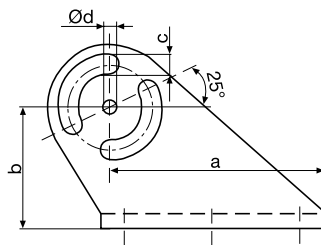

Draufsicht
topview

Winkel/Angle	a	b	c	Ød*	e	f	g	h	i	k
für/for KI/RG15 Art.-Nr. / Art.no. 220150002	54	35	5,5	3,2	32	25	6,4	4	15	7
für/for RG20/22 Art.-Nr. / Art.no. 220200002	56	35	5,5	3,2	40	35	6,4	4	21	9
für/for RG30 Art.-Nr. / Art.no. 220300002	61	35	5,5	3,2	50	40	6,4	4	21	14

* bei Bedarf aufbohren / bore hole if necessary

Verbindungselemente / fastening devices

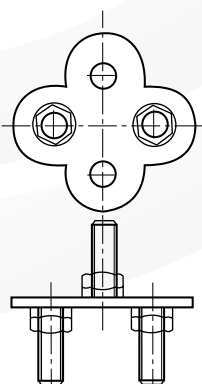

90° Verbindungselement *¹
90° Fastening device
Art.Nr.: 220000005

*¹ zur Befestigung werden zwei Laschen benötigt
Art.Nr.: 220000013 /
for fixation two clips are
necessary
Art.no. 220000013

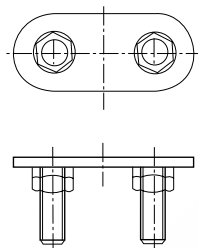

Schloss/Link *²
Art.Nr.: 220000012

*² zur Befestigung wird eine Lasche benötigt
Art.Nr.: 220000013 /
for fixation one clip Art.no. 220000013 is necessary

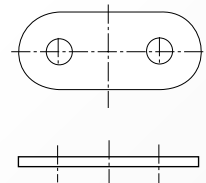

Lasche/Clip
Art.Nr.: 220000013

Technische Daten / Technical specifications

Führungs-Rollen / Guide rolls

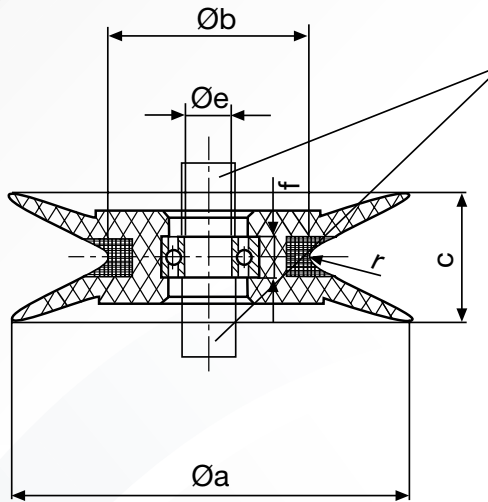

Zugehörige Buchsen (2 Stck.)
accessory bushings (2 pcs.)



Maße / Dimensions

Führungsrollen / Guide rolls

Buchsen / Bushings

Art.-Nr. Art.-no	Bez. Desc.	Ø a	Ø b	c	Øe	f	r	Art.-Nr. Art.-no.	Ø innen inner dia	Ø aussen outer dia	Breite width
620001001	UA 1001	20,0	15,5	5,0	3,0	3,0	0,5	220000020	3,2	4,0	2,0
620001002	UA 1002	30,0	20,5	6,0	4,0	4,0	1,0	220000021	4,2	6,0	3,0
620001004	UA 1004	40,0	20,0	14,5	4,0	4,0	1,0	220000023	4,2	6,0	6,5
620001005	UA 1005	45,0	29,5	10,5	6,0	6,0	1,0	220000024	6,2	10,0	4,0
620001006	UA 1006	60,0	41,5	12,5	8,0	7,0	1,0	220000025	8,2	12,0	4,0
620001007	UA 1007	60,5	29,5	20,0	6,0	6,0	1,0	220000026	6,2	10,0	8,0
620001008	UA 1008	80,0	50,0	16,5	10,0	9,0	2,0	220000027	10,2	16,0	5,0
620001009	UA 1009	80,0	39,5	25,0	8,0	7,0	1,0	220000028	8,2	12,0	10,0
620001010	UA 1010	100,0	50,0	29,0	10,0	9,0	2,0	220000029	10,2	16,0	11,0

Änderungen vorbehalten

Subject change without notice



Worldwide

The addresses of our agencies are available in the internet:
www.uhing.com

Weltweit

Die Adressen unserer Fachvertretungen finden Sie im Internet:
www.uhing.com



National Head Office

7 Hargreaves Street
Belmont, WA 6109
Ph: (08) 9475 5000
linear@statewidebearings.com.au

902 Beaudesert Road
Coopers Plains QLD 4108
Ph: (07) 3717 4452
linearqld@statewidebearings.com.au

9-11 Kilkenny Court,
Dandenong South, Vic 3175
Ph: (03) 9755 6044
linearcvic@statewidebearings.com.au

Unit 4, 8 Cooper Street
Smithfield, NSW 2164
Ph: (02) 9616 0066
linearnsw@statewidebearings.com.au

13 Streiff Road
Wingfield, SA 5013
Ph: (08) 8260 6299
linearsa@statewidebearings.com.au

Joachim Uhing GmbH & Co. KG

Kieler Straße 23
24247 Mielkendorf, Germany
Telefon +49 (0) 4347 - 906-0
Telefax +49 (0) 4347 - 906-40 e-mail: sales@uhing.com Internet:
www.uhing.com

