



Rollringgetriebe
Rolling Ring Drives



Führungssystem
Guide System



Wälzmutter
Linear Drive Nut



Zahnriemenantriebe
Timing Belt Drives



Klemm- und Spannelemente
Clamping Systems



Verlegesysteme
Winding Systems

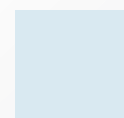
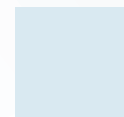
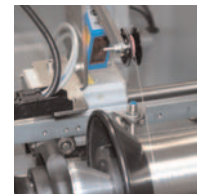

FA II Flange Detecting System

Application

The flange detecting system detects the position of flanges on spools, regardless of the spool used. After a spool change, the system automatically adjusts to the new spool position and, where necessary, the new spool shape.

The flange detecting system was specially designed for application with pneumatically reversible rolling ring drives but can also be fitted on other traversing systems after testing.

Principle of Function

The sensor detecting the flange is mounted on the traversing system. At a defined point, the current distance is captured and saved as reference distance for each single layer.

While the traversing system moves, the reference distance is continuously compared to the measured value. A reversal is triggered as soon as the permissible, adjustable height deviation is exceeded. Such a height deviation occurs when the flange or an accumulation of material on the spool is detected.

A display indicates either the measured height or the permissible height deviation.

Areas of application

The system has been designed for laying round material with diameters of 0.1 to 2.0 mm on cylindrical spools. Other dimensions are possible after consultation.

Spools of different sizes can be wound without readjustment. In this context, the diameters of the spool core (d_{core}) and the flanges (d_{flange}) must be heeded. The difference must not exceed 220 mm ($d_{\text{flange}} - d_{\text{core}} < 220 \text{ mm}$).

When using several spools, the smallest core diameter and the largest flange diameter applies. Other spool sizes are possible as variant.

Flanges can be rectangular or conical up to an angle of 40°; the bulging of flanges is compensated for. Scanning of spools with collapsed flanges is not possible.

The traversing system must be mounted parallel to the spool axis. For very slow winding speeds, the radial run-out of the shaft carrying the spool shall be smaller than the smallest diameter of the material to wind.

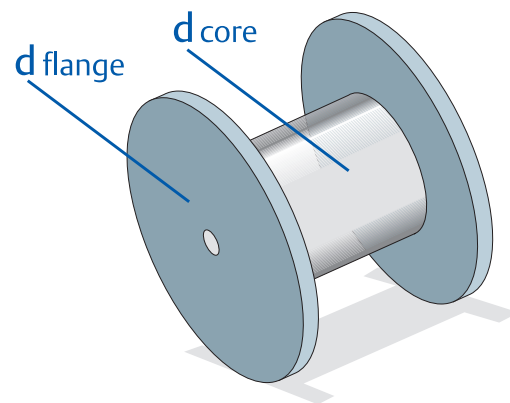
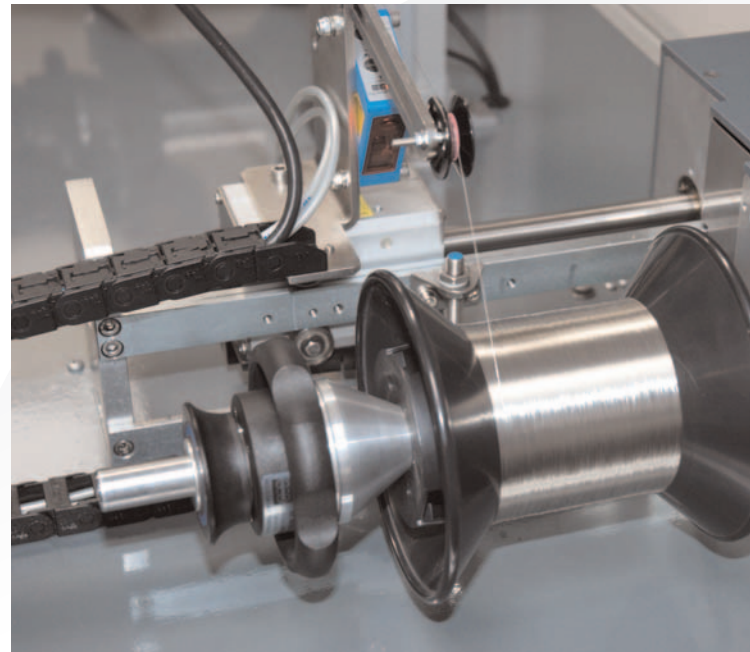

Your Advantage

- No manual adjustment of reversal points
- Significant time savings when spools of different type and dimension are used, because adjustment is not required
- Very easy operation
- No prior experience required
- Perfect winding patterns
- No machine data required from customer
- Robust sensor technology
- Modular system

Installation and Integration

The flange detecting system does not require any signals from the machine but can process the floating start signal of the machine to reset the measurement after a spool change. Resetting is also possible with a pushbutton on the controller. Valves for pneumatic reversal can be connected and/or the signals “flange detected”, “counter clockwise”, “clockwise”, and “error” can be provided to the machine controller.



The flange detecting sensor is mounted below or above the material guide and aligned to the spool centre once. The minimum distance to the flange is 65 mm, the maximum distance to the spool core is 175 mm for the standard variant.

Scope of delivery

The system uses tried and tested industrial components only, ensuring a high quality and long-term spare parts availability.

- 1 sensor for flange detection, with 3.5 m connecting cable, pluggable
- Holder for flange detecting sensor to which a guide system adapted to the rolling ring drive can be mounted, universally applicable
- Energy chain for hoses and cables
- 1 sensor for reference point detecting with 2 m connecting cable



- Universal holder for reference point detecting sensor
- 1 switch box with controller, display, reset pushbutton, adjuster for permissible height deviation
- Comprehensive Operating and Installation Instructions

Technical Data

- Supply voltage: 24 VDC, 2 A
- Ambient temperature range -10 ° to 40 °C
Max. humidity 95%, non-condensing
- Protection class of flange detecting sensor: IP 65
- Switch box dimensions w x h x d: 300 x 200 x 120 mm, cable exit at bottom, d+30 mm for controls; vertical installation; IP54 protection (IP65 upon request)
- 2 shielded valves, 24 V, 0.1 A, can be connected, see Options
- Signals for machine control and alarm indication: flange pulse detected, counter clockwise, clockwise, error
- Flange detecting sensor: Laser Class II acc. to IEC 60825-1

Maintenance

The system is maintenance-free; in dust-laden atmospheres, the aperture of the flange detecting sensor should be cleaned from time to time, or a protective enclosure should be used.

Options

- Protective sensor enclosure with compressed air connection as cleaning device and pressure governor unit
- Pneumatic kit, consisting of fast-action valve, mounting bracket, connecting cables and hoses
- Guide system from our GS range
- Installation and commissioning support



Worldwide

The addresses of our agencies are available in the internet:
www.uhing.com



National Head Office

7 Hargreaves Street
Belmont, WA 6109
Ph: (08) 9475 5000
linear@statewidebearings.com.au

902 Beaudesert Road
Coopers Plains QLD 4108
Ph: (07) 3717 4452
linearqld@statewidebearings.com.au

9-11 Kilkenny Court,
Dandenong South, VIC 3175
Ph: (03) 9755 6044
linearvic@statewidebearings.com.au

Unit 4, 8 Cooper Street
Smithfield, NSW 2164
Ph: (02) 9616 0066
linearnsw@statewidebearings.com.au

13 Streiff Road
Wingfield, SA 5013
Ph: (08) 8260 6299
linearsa@statewidebearings.com.au

Joachim Uhing GmbH & Co. KG
Kieler Straße 23
24247 Mielkendorf, Germany Phone
+49 (0) 4347 - 906-0 Fax +49
(0) 4347 - 906-40 e-mail:
sales@uhing.com Internet:
www.uhing.com

