

Rotary Ball Spline Model LTR

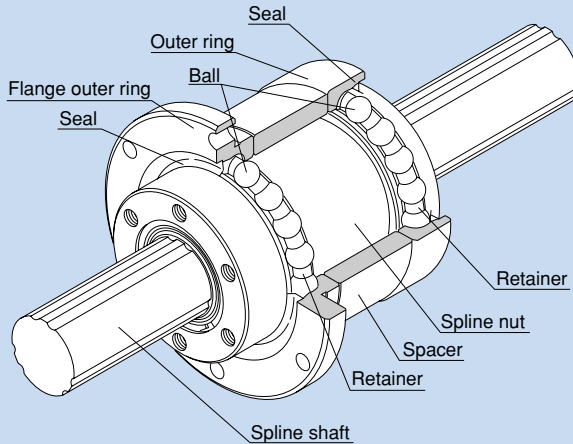

Fig. 1 Structure of Rotary Ball Spline Model LTR

● Structure and Features

With rotary Ball Spline model LTR, the spline shaft has three crests on the circumference, and along both sides of each crest, two rows of balls (six rows in total) are arranged to hold the crest so that a reasonable preload is applied.

Angular-contact ball raceways are machined on the outer surface of the spline nut to constitute support bearings, allowing the whole body to be compactly and lightly designed.

The rows of balls are held in a special resin retainer so that they smoothly roll and circulate. With this design, balls will not fall even if the spline shaft is removed.

In addition, a dedicated seal for preventing foreign matter from entering the support bearings is available.

● No Angular Backlash

Two rows of balls facing one another hold a crest, formed on the circumference of the spline nut, at a contact angle of 20° to provide a preload in an angular-contact structure. This eliminates an angular backlash in the rotational direction and increases the rigidity.

● Compact design

The spline nut is integrated with the support bearings, allowing highly accurate, compact design to be achieved.

● Easy installation

This ball spline can easily be installed by simply securing it to the housing using bolts.

● High Rigidity

Since the contact angle is large and an appropriate preload is given, high rigidity against torque and moment is achieved. The support bearing has a contact angle of 30° to secure high rigidity against a moment load, thus to achieve a rigid shaft support.

Model LTR-A, a compact type of LTR, has a contact angle of 45° .

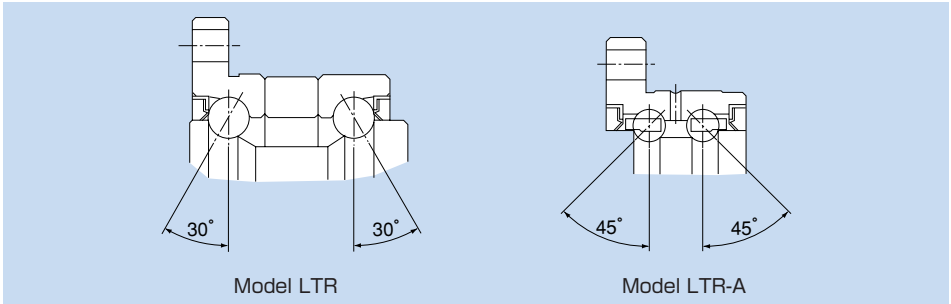

● Types and Features

● Types of Spline Nuts

Ball Spline Model LTR



A compact unit type whose support bearings are directly integrated with the outer surface of the spline nut.

Ball Spline Model LTR-A



A compact type even smaller than LTR.

● Types of Spline Shafts

For details on spline shaft types, see page b-45.

Housing Inner-diameter Tolerance

For the housing inner-diameter tolerance for model LTR, class H7 is recommended.

Spline Shaft

Spline shafts are divided in shape into precision solid spline shaft, special spline shaft and hollow spline shaft (types K and N), as described on page b-45.

Since production of a spline shaft with a specific shape is performed at your request, provide a drawing of the desired shaft shape when asking an estimate or placing an order.

Sectional Shape of the Spline Shaft

Table 1 shows the sectional shape of a spline shaft. If the spline shaft ends need to be cylindrical, the minor diameter (d) value should not be exceeded if possible.

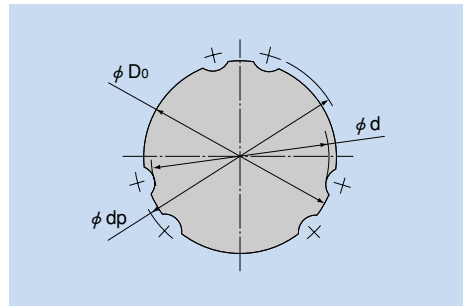

Table 1 Sectional Shape of the Spline Shaft

Unit: mm

Nominal shaft diameter	8	10	16	20	25	32	40	50	60
Minor diameter d	7	8.5	14.5	18.5	23	30	37.5	46.5	56.5
Major diameter D_0 h7	8	10	16	20	25	32	40	50	60
Ball center diameter d_p	9.3	11.5	17.8	22.1	27.6	35.2	44.2	55.2	66.3
Mass (kg/m)	0.4	0.62	1.6	2.5	3.9	5.6	9.9	15.5	22.3

● Hole Shape of the Standard Hollow Type Spline Shaft

Table 2 shows the hole shape of the standard hollow type spline shaft (types K and N). Use this table when a requirement such as piping, wiring, air-vent or weight reduction needs to be met.

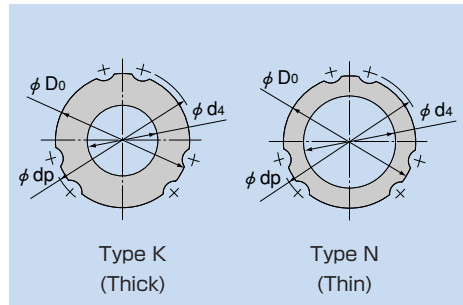

Table 2 Sectional Shape of the Standard Hollow Type Spline Shaft

Unit: mm

Nominal shaft diameter	8	10	16	20	25	32	40	50	60	
Major diameter D_0	8	10	16	20	25	32	40	50	60	
Ball center diameter d_p	9.3	11.5	17.8	22.1	27.6	35.2	44.2	55.2	66.3	
Type K	Hole diameter d_4	3	4	7	10	12	18	22	25	32
	Mass (kg/m)	0.35	0.52	1.3	1.8	3	4.3	6.9	11.6	16
Type N	Hole diameter d_4	—	—	11	14	18	23	29	36	—
	Mass (kg/m)	—	—	0.8	1.3	1.9	3.1	4.7	7.4	—

Note: The standard hollow type Spline Shaft is divided into types K and N. Indicate "K" or "N" at the end of the model number to distinguish between them when placing an order.

● Chamfering of the Spline Shaft Ends

For details of chamfering of the spline nut ends, see page b-24.

● Length of Incomplete Section of a Special Spline Shaft

If the middle area or the end of a spline shaft is to be thicker than the minor diameter (d), an incomplete spline section is required to secure a recess for grinding. Table 3 shows the relationship between the length of the incomplete section (S) and the flange diameter (df). (This table does not apply to overall length of 1,500 mm or greater. Contact THK for details.)

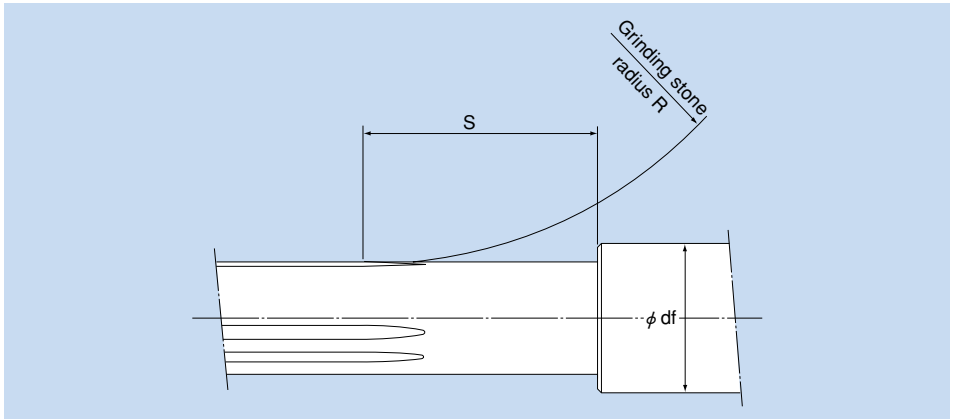
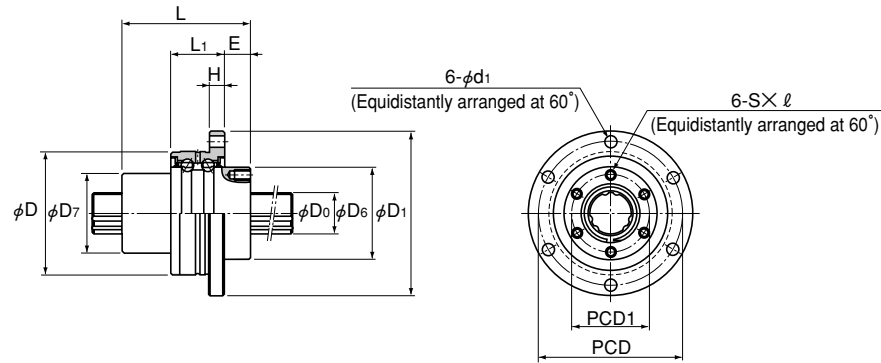

Table 3 Length of Incomplete Spline Section: S

Unit: mm

Flange diameter df	6	8	10	13	16	20	25	30	40	50	60	80	100	120	140	160
Nominal shaft diameter																
8	—	16	24	30	35	—	—	—	—	—	—	—	—	—	—	—
10	—	—	17	27	32	37	—	—	—	—	—	—	—	—	—	—
16	—	—	—	—	21	36	46	54	—	—	—	—	—	—	—	—
20	—	—	—	—	—	21	38	48	62	—	—	—	—	—	—	—
25	—	—	—	—	—	—	23	39	56	67	—	—	—	—	—	—
32	—	—	—	—	—	—	—	24	49	62	72	—	—	—	—	—
40	—	—	—	—	—	—	—	—	27	50	63	81	—	—	—	—
50	—	—	—	—	—	—	—	—	—	29	51	74	89	—	—	—
60	—	—	—	—	—	—	—	—	—	—	28	56	71	82	—	—



Model LTR16A or greater

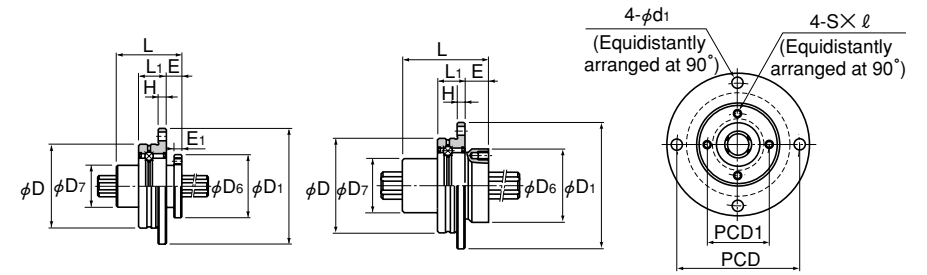

Model LTR8A

Model LTR10A

Model LTR8A

Model LTR10A

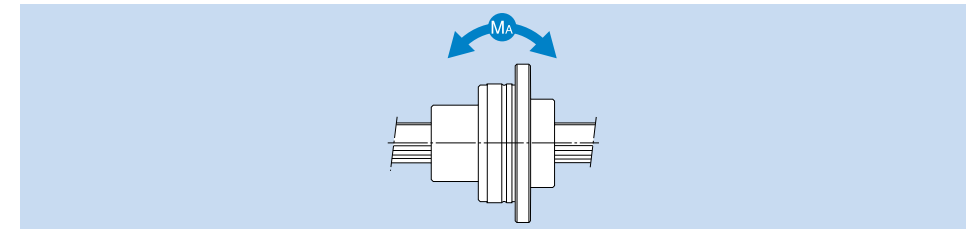

Unit: mm

Model No.	Outer diameter		Length	Spline nut dimensions										Spline shaft diameter	Basic torque rating		Basic load rating		Permissible static moment	Support bearings basic load rating		Mass			
	D	Tolerance		D ₆	D ₇	H	L ₁	E	E ₁	PCD	PCD1	Sx l	d ₁		C _T	C _{OT}	C	C ₀		M _A *	C	C ₀	Spline nut	Spline shaft	
			D ₁	h7									h7	No. of rows of balls	N·m	N·m	KN	KN	N·m	KN	KN	kg	kg/m		
LTR 8A	32	-0.009	25	44	24	16	3	10.5	6	3	38	19	M2.6X3	3.4	8	4	1.96	2.94	1.47	2.55	5.9	0.69	0.24	0.08	0.4
LTR 10A	36	-0.025	33	48	28	21	3	10.5	9	—	42	23	M3X4	3.4	10	4	3.92	7.84	2.84	4.9	15.7	0.77	0.3	0.13	0.62
LTR 16A	48		50	64	36	31	6	21	10	—	56	30	M4X6	4.5	16	6	31.3	34.3	7.05	12.6	67.6	6.7	6.4	0.35	1.6
LTR 20A	56	-0.010	63	72	43.5	35	6	21	12	—	64	36	M5X8	4.5	20	6	56.8	55.8	10.2	17.8	118	7.4	7.8	0.51	2.5
LTR 25A	66	-0.029	71	86	52	42	7	25	13	—	75	44	M5X8	5.5	25	6	105	103	15.2	25.8	210	9.7	10.6	0.79	3.9
LTR 32A	78	-0.012	80	103	63	52	8	25	17	—	89	54	M6X10	6.6	32	6	180	157	20.5	34	290	10.5	12.5	1.25	5.6
LTR 40A	100	-0.034	100	130	79.5	64	10	33	20	—	113	68	M6X10	9	40	6	418	377	37.8	60.4	687	16.5	20.7	2.51	9.9

***Note** M_A indicates the permissible moment value in the axial direction when a single spline nut is used, as shown in the figure above.

Model number coding

2 LTR32A K UU ZZ CL +500L P K

- 1 Number of spline nuts on one shaft (no symbol for one nut)
- 2 Model No.
- 3 Flange orientation symbol - no symbol: standard; K: flange inverted
- 4 Spline nut dust prevention accessory symbol - no symbol: without seal
UU: rubber seal attached on both ends of spline nut
U: rubber seal attached on either end of spline nut
- 5 Support bearings dust prevention accessory symbol - no symbol: without seal
ZZ: rubber seal attached on both ends of support bearings
Z: rubber seal attached on either end of support bearings
- 6 Symbol for clearance in the rotational direction (see page b-4)
- 7 Overall spline shaft length (in mm)
- 8 Accuracy symbol (see page b-5)
- 9 Symbol for standard hollow spline shaft (see page b-69) (no symbol: solid spline shaft)

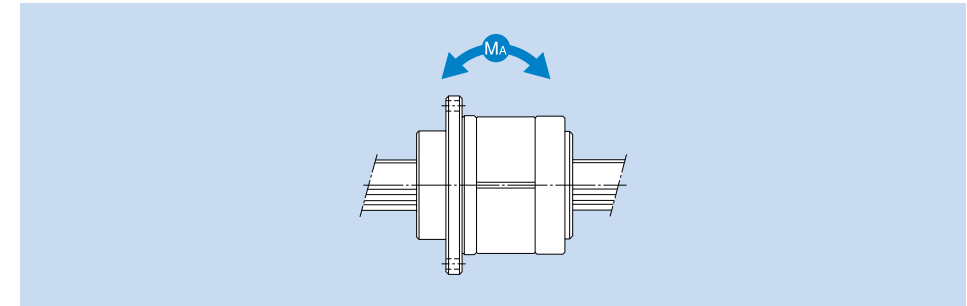
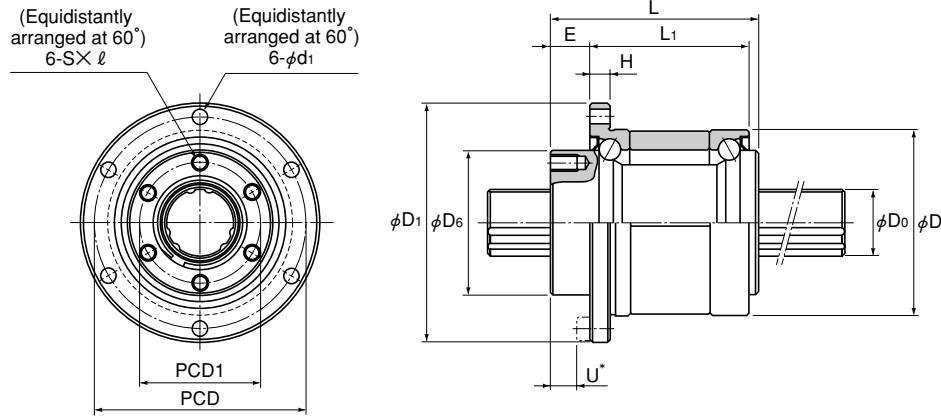

Unit: mm

Model No.	Outer diameter		Length L	Spline nut dimensions							Spline shaft diameter	No. of rows of balls	Basic torque rating		Basic load rating		Permissible static moment	Support bearings basic load rating		Mass				
	D	Tolerance		Flange diameter D ₁	D ₆ h7	H	L ₁	E	PCD	PCD1			S x l	d ₁	U*	D ₀ h7		C _T N·m	C _{OT} N·m	C KN	C _O KN	M _A * N·m	C kN	C _O kN
LTR 16	52	0 -0.007	50	68	39.5	5	37	10	60	32	M5x8	4.5	5	16	6	31.4	34.3	7.06	12.6	67.6	12.7	11.8	0.51	1.6
LTR 20	56		63	72	43.5	6	48	12	64	36	M5x8	4.5	7	20	6	56.9	55.9	10.2	17.8	118	16.3	15.5	0.7	2.5
LTR 25	62		71	78	53	6	55	13	70	45	M6x8	4.5	8	25	6	105	103	15.2	25.8	210	17.6	18	0.93	3.9
LTR 32	80	0 -0.008	80	105	65.5	9	60	17	91	55	M6x10	6.6	10	32	6	180	157	20.5	34	290	20.1	24	1.8	5.6
LTR 40	100		100	130	79.5	11	74	23	113	68	M6x10	9	13	40	6	419	377	37.8	60.5	687	37.2	42.5	3.9	9.9
LTR 50	120		125	156	99.5	12	97	25	136	85	M10x15	11	13	50	6	842	769	60.9	94.5	1340	41.7	54.1	6.7	15.5
LTR 60	134	-0.009	140	170	115	12	112	25	150	100	M10x15	11	13	60	6	1220	1040	73.5	111.7	1600	53.1	68.4	8.8	22.3

***Note** M_A indicates the permissible moment value in the axial direction when a single spline nut is used, as shown in the figure above.
Dimension U represents the dimension from the head of the hexagon socket screw to the spline nut end.

Model number coding

2 LTR**50** K **UU** **ZZ** **CM** **+1000L** **H** **K**

- 1 Number of spline nuts on one shaft (no symbol for one nut)
- 2 Model No.
- 3 Flange orientation symbol - no symbol: standard; K: flange inverted
- 4 Spline nut dust prevention accessory symbol - no symbol: without seal
UU: rubber seal attached on both ends of spline nut
U: rubber seal attached on either end of spline nut
- 5 Support bearings dust prevention accessory symbol - no symbol: without seal
ZZ: rubber seal attached on both ends of support bearings
Z: rubber seal attached on either end of support bearings
- 6 Symbol for clearance in the rotational direction (see page b-4)
- 7 Overall spline shaft length (in mm)
- 8 Accuracy symbol (see page b-5)
- 9 Symbol for standard hollow spline shaft (see page b-69) (no symbol: solid spline shaft)